

Airblast B.V.
 P.O. Box 1075
 1700 BB Heerhugowaard
 The Netherlands
 Tel. : +31 72-5718002
 Fax : +31-72-5714340
 E-mail : info@airblast.com

Technical Information
The Art of Powerful Cleaning...

Date: 09.2003

Title: Conversion Pipecoater-III/300 to Pipecoater-III/900

1. Remove centering carriage (item 14) and 2 pcs. lock nut (item 15) from Pipecoater.
2. Remove tip/filter assy (items 23, 24, 25 and 26) from inlet housing (item 7).

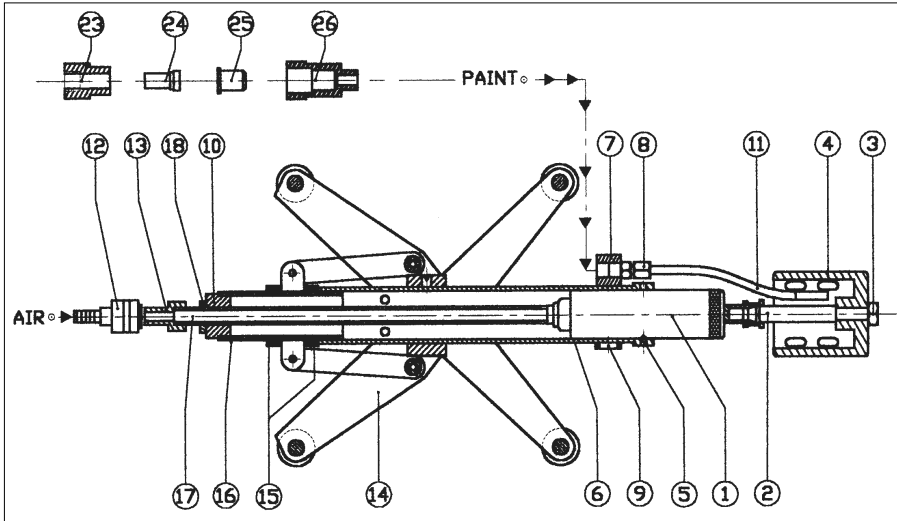

3. Assemble the bushing (item 14) onto the Pipecoater (see drawing below).
4. Assemble coupling (item 8) onto the inlet housing.
5. Assemble brass paint tube (item 21) onto the coupling (item 8).
6. Assemble coupling (item 8) onto brass paint tube (item 21).
7. Assemble aluminium tube holder (item 19) between the nut (item 18) and the rear end plate (item 10).
8. Use nut (item 20) to assemble tip/filter assy (items 23, 24, 25 and 26) to coupling (item 8).
9. Now you should be able to assemble the centering collars (item 15), centering legs (item 27) and the arms with wheels (item 22). The Pipecoater-III/900 is ready for use.

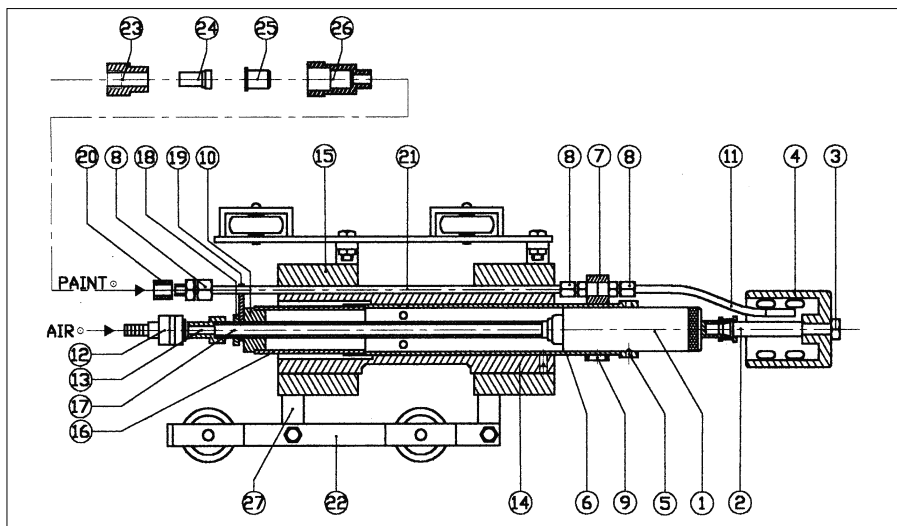

PARTS REQUIRED FOR CONVERSION:

01.	73130	Bushing	1 pc.
02.	73122	Coupling 1/4" x 8 mm	2 pcs.
03.	73144	Paint tube brass 330 mm	1 pc.
04.	73142	Aluminium tube holder	1 pc.
05.	73143	Nut	1 pc.
06.	30590	Centering collars	2 pcs.
07.	30570	Arms with wheels	3 pcs.
08.	30580	Set of centering legs (4 x 6 pcs.)	1 pc.