

OWNER'S MANUAL

AIRTRANS PORTABLE VACUUM RECOVERY SYSTEM

IMPORTANT WARNING FOR SAFER WORKING

1. Check for possible silicosis hazards. Avoid dust.
2. Use only proper dry and well-screened abrasives specifically intended for blasting.
3. Before use:
 - Check fittings and hose for wear.
 - Safety-wire couplings together.
4. Do not weld on blast machine, this voids Airblast and safety organization approval.
5. Do not substitute Airblast parts or modified equipment in any way.



AIRBLAST B.V.

P.O. Box 1075
1700 BB Heerhugowaard
The Netherlands
Tel. : + 31-72-5718002
Fax : + 31-72-5714340
E-mail : info@airblast.com
Web : www.airblast.cm

1.0 INTRODUCTION.

1.1 General description: The Airtrans has been designed to be an easy tool to use. By understanding two simple set-ups you can discover an endless number of applications for your vacuum tool.

1.2 The first set-up method we call the direct transfer mode. In this mode, material actually being pulled into the Airtrans under vacuum and discharged out of the Airtrans under pressure.

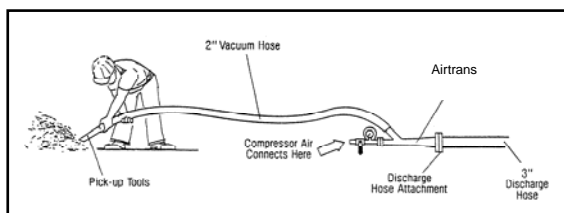

For situation where the discharged material need to be controlled, simply attach a vacuum hose to the 2" vacuum port on the Airtrans and the material will be pulled into the unit and discharged out of the end. When material must be moved some distance and then deposited in a specific place such as a truck, bin or pile, discharge hose can be connected to the flanged end of the Airtrans using the Discharged Hose Attachment accessory. Hose with less than 3" diameter should not be used. It is important to minimize bends, ups and downs. It is also easier to push a long distance then to pull. For example, when moving material 30 meters, it is better to pull (vacuum) 20 and to push 80 than to pull 80 and push 20. Generally speaking, material being discharged from the unit is at a fairly high velocity, so concern must be given to potential for abrasion and the lack of ability to control any dust created by the material movement.

1.3 The second basis set-up method we term the drum transfer mode. When material must be controlled or saved, a vacuum hose is attached between the Airtrans and the container to be filled and another hose runs from the container to the material being picked-up.

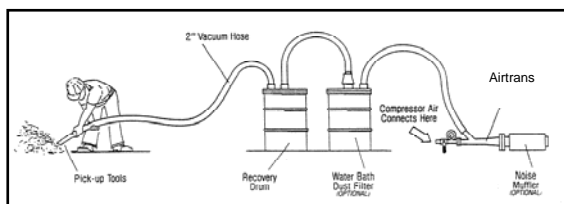

Because a vacuum is pulled on the container, it is important there be no air leaks and that a good seal be maintained between the transfer lid and the container. The pick-up hose is always attached to the outside port of the container lid, the vacuum hose from the Airtrans unit to the center port. Unlike the direct transfer mode, it is possible to add dust and noise control in the drum transfer mode. Vacuum can be pulled on a 200 ltr. Drum, or any other container of your choice, provided it is properly modified.

1.4 It should also be mentioned here that the Airtrans will not perform satisfactorily in either of the above configurations if the material to be vacuumed will not visually flow. A simple, quick check is to take a hand full of the product and compress it in your grip. When your grip is released, if the material will not flow through your fingers, it will not move effectively via vacuum. In addition, if the material has no natural slump to it (i.e. flour consistency vs granular sugar consistency) and will not flow to the tool at the pickup point – it will move fine once entrained in the air stream but will probably need to be agitated at the pickup point in order to keep the flow constant.

2.0 SET-UP AND OPERATION

2.1 You have purchased an air-driven vacuum tool that will give you uninterrupted service as long as you give a little bit of attention to a few details:

1. Air is obviously the power supply, so attention should be paid to the amount of pressure of the air input required. When dealing with material in the 100 lb./cu.ft. range or heavier, 200 CFM air at 100 PSI is required to maintain satisfactory production rates. With lighter materials, less pressure and air volume is needed. Refer to the CFM/PSI chart included in these instructions.
2. In conjunction with the air requirements goes the topic of air supply line. In order to take full advantage of the compressor output, we can recommend a minimum of 1 1/4" air supply line. If you are running 3/4" air line, two lines can be tee'd into the Airtrans air supply port to assure that the unit will be provided with the CFM needed to operate most efficiently. As with any air driven tool, hose bends and total length should be kept to a minimum. Keep in

AIRTRANS PORTABLE VACUUM RECOVERY SYSTEM

mind that it is the smallest restriction in the air supply system that counts. It does no good to attach 1 ¼" line to ½" fitting.

3. Maintenance of a couple of key internal parts will insure the long life of your unit. A daily visual check of only two parts is all that is needed. Number one is a check of the air nozzle by simply looking into the vacuum intake port. When the black rubber boot over the nozzle begins to show excessive wear, either rotate the boot or replace the boot with another. The second item to check is the wear liner. The wear liner sits on a ledge inside the Airtrans. Check by looking into the exhaust port. When the liner wears to the edge it is time for replacement. When replacing be sure that the slot in the liner is in alignment with the vacuum port in the venturi casting. Also be sure that the rubber washer is positioned between the liner and the air nozzle casting.

NOTE

WEAR OCCURS ONLY IN THE DIRECT TRANSFER MODE WHERE MATERIAL IS PASSING THROUGH THE VENTURI. IF YOU ARE PULLING MATERIAL INTO A CONTAINER AHEAD OF THE VACUUM AS IN THE DRUM TRANSFER MODE, WEAR IS NOT A CONCERN.

SHOULD EITHER THE NOZZLE OR LINER WEAR THROUGH AND REMAIN UNCHECKED, THE BASIC VENTURI CASTING WILL DESTROY IN A MATTER OF HOURS, DEPENDING ON THE MATERIAL BEING CONVEYED, AND WILL HAVE TO BE REPLACED AT SUBSTANTIALLY MORE COST THAN THE MAINTENANCE PARTS.

4. Safety considerations include staying clear of the exhaust port when pumping material directly through the unit. Also, under certain conditions static electricity will build-up and discharge from the conveying hoses. This can be more of a nuisance than anything, but at times could pose a danger to the worker. Grounding of the hoses and tools will solve the problem. It should also be mentioned that in the drum recovery mode, it is possible to collapse the drum under vacuum if the

hose clogs with material. Again, this is more of a nuisance than a danger. To avoid this be sure to use the proper pick-up tools or be visually sure material is entering the vacuum hose at the proper rate.

5. A comment on the state of material Airtrans will convey. Materials with a piece size greater than ½" in diameter cannot be pumped directly through the unit. Dry material or liquid and slurry material will convey. Anything that visually will not flow can probably not be conveyed by the Airtrans.

3.0 TROUBLESHOOTING

In the event that your Airtrans does not perform as you expect or ceases to perform properly during operation, please check the following:

- Compressor too small (not enough CFM and/or PSI)
- Too small diameter air line
- Leak in air line
- Air line too long
- Too many bends in air line
- Obstructions in air line
- Obstruction in air nozzle
- Leak in vacuum hose
- Obstruction in vacuum hose
- Too many bends in vacuum hose
- Obstruction in vacuum tool
- Obstruction in unit
- Wear liner in place off-center
- Material too damp to flow
- Drum transfer mode – drum lid not sealing properly
- Obstruction in exhaust hose
- Too many bends in exhaust hose
- Material too heavy
- Using vacuum with no pick-up tool attached.

AIRTRANS PORTABLE VACUUM RECOVERY SYSTEM

4.0 CFM / PSI CHART

Being an air-driven tool, it is important to understand that the vacuum power as well as the rate of material movement through the vacuum system is affected by the amount in volume and the pressure of the air supplied to the Airtrans. For your help in understanding this, below is a chart relating the pressure reading on the air gauge to the amount of CFM going through the air nozzle at the pressure (i.e. at 100 PSI, the Airtrans will consume 200 CFM of air, at 50 PSI, it will consume 140 CFM of air).

PSI READING	CFM CONSUMED
1	20
5	45
10	63
20	89
30	109
40	126
50	140
60	155
70	167
80	180
90	190
100	200

Another way to look at the above figures is also to say for example that if you only have 155 CFM compressor available to drive the Airtrans, you will only be able to maintain 60 PSI against the tool which may or may not generate enough vacuum to pick-up the particular product with which you are dealing.

The lighter the product the less vacuum power is required. At 100 lbs. per cubic foot material we ideally need all of the 100 PSI pressure to produce satisfactory movements rates.

AIRTRANS PORTABLE VACUUM RECOVERY SYSTEM

5.0 SPARE PARTS

ART.NR.	MODEL	DESCRIPTION
32000	Airtrans/S	AIRTRANS, SINGLE EXECUTION Recovery unit for spend abrasives. Suction side 2" – Discharge side 3".
32005	Airtrans/D	AIRTRANS, DOUBLE EXECUTION Recovery unit for spend abrasives. Suction side 2" – Discharge side 3".
32100		Manifold kit (combines two Airtrans units)
32105		Discharge Hose Attachment (for 3" discharge hose)
32150		Small brush tool
32155		Brush floor tool with wand
32200		Small gulper tool
32205		Floor gulper with wand
32210		Crevice tool
32215		Short 2" carburetor pick-up probe
32220		Long 2" carburetor pick-up probe
32225		3" carburetor pick-up probe
32235		Leg assembly (not shown)
1) 32240		Nozzle holder casting
2) 32245		Venturi body casting
3) 32250		Replacement liner
4) 32255		Nozzle tip with ceramic cover (extra long wear)
32260		Nozzle tip with rubber cover
5) 32265		Pressure gauge
6) 32270		Gauge mount
7) 32275		Ball valve
32280		Nozzle tip cover – rubber (pack of 5)
8) 32340		Camlock set 2"
		AIRTRANS VACUUM HOSE Flexible polyurethane hose with highly rigid pvc spiral
32310		2" Airtrans hose (p/mtr.)
32320		3" Airtrans hose (p/mtr.)

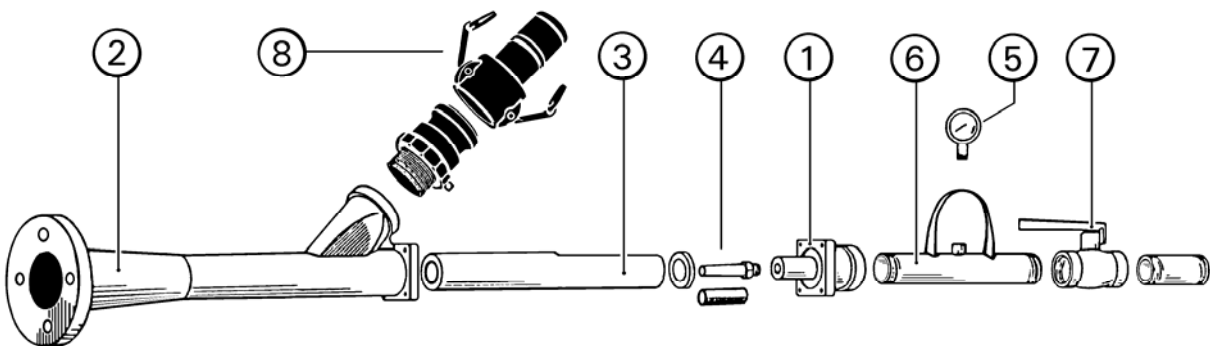

AIRTRANS PORTABLE VACUUM RECOVERY SYSTEM

CONFIGURATION 1:

Sand recovery into standard 200 ltr. drum with optional dust and noise control.

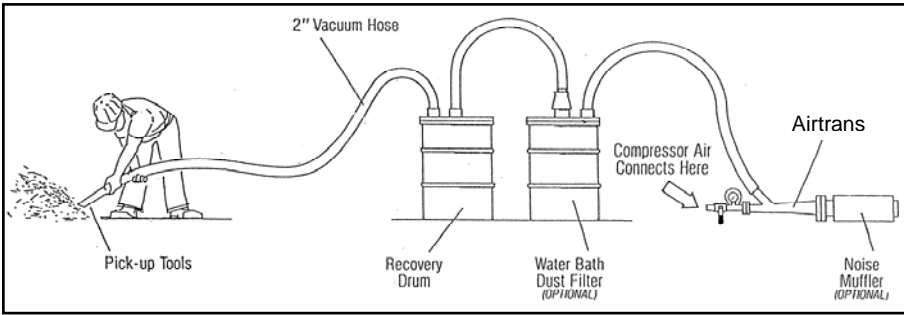

CONFIGURATION 2:

Sand recovery into dump hopper mounted above larger container or conveyor with optional dust and noise control.

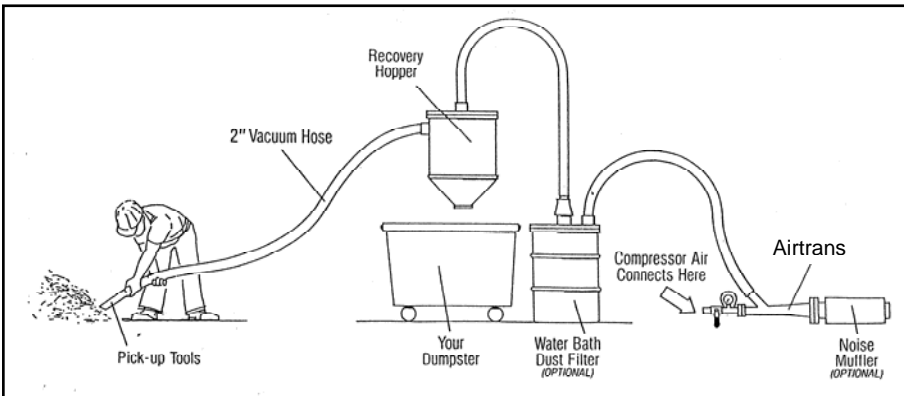

CONFIGURATION 3:

Sand recovery into 200 ltr. drum or dump hopper using your dust collection system for dust and noise control (drum shown)

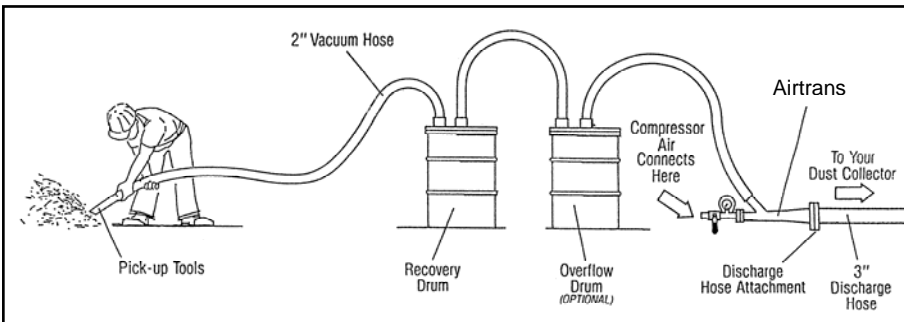

CONFIGURATION 4:

Direct transfer mode, discharging sand into large container or into loose pile.

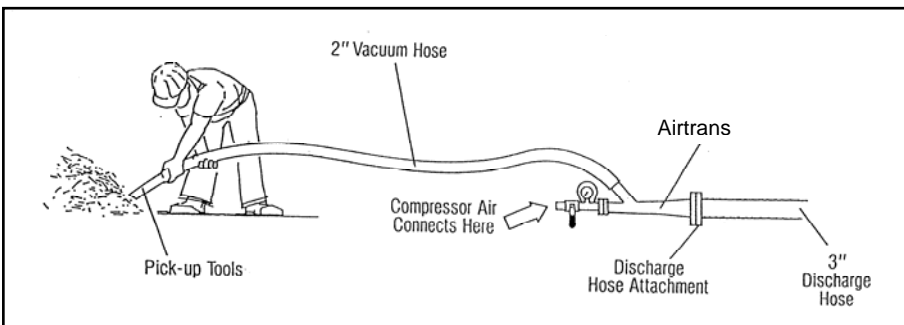

Airblast Group

Airblast B.V.

P.O. Box 1075
1700 BB Heerhugowaard
The Netherlands
Tel. : + 31 72 5718002
Fax : + 31 72 5714340
E-mail : info@airblast.com
Web : www.airblast.com

Airblast Middle East L.L.C.

P.O. Box 33419
Dubai
United Arab Emirates
Tel. : + 971 4 3242776
Fax : + 971 4 3242778
E-mail : airblast@emirates.net.ae

Airblast Saudi Arabia

P.O. Box 30476
Al-Khobar 31952
Kingdom of Saudi Arabia
Tel. : + 966 3 8473178
Fax : + 966 3 8471430
E-mail : info@airblast.com.sa

Asia Airblast Pte Ltd.

56, Tech Park Crescent
Tuas Tech Park
Singapore 638085
Tel. : + 65 6266 6010
Fax : + 65 6266 6968
E-mail : airblastsg@singnet.com.sg

AB Corrosion Control Equipment Sdn Bhd

No. 33, Jalan Permas 3/18
Bandar Baru Permas Jaya
81750 Masai, Johor Darul Takzim
Malaysia
Tel. : + 60 7357 7989
Fax : + 60 7357 7689
E-mail : airblastmy@airblastasia.org