

OWNER'S MANUAL

EDUCT-O-MATIC

IMPORTANT WARNING FOR SAFER BLAST CLEANING

1. Tool operator and anyone within 50 feet of work area must wear safety goggles.
2. Check for possible silicosis or other toxic hazards.
3. Do not blast with damaged or worn equipment.
4. Point nozzle only at area being cleaned.
5. Use only proper dry and well-screened abrasives specifically intended for blasting.
6. Keep unprotected workers out of the blast area.
7. Before blasting check fittings and hose for wear.
8. Do not substitute for parts from other manufacturers, or modified equipment in any way.

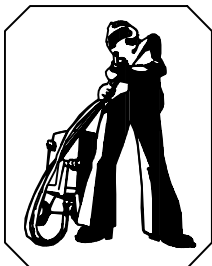

AIRBLAST B.V.

P.O. Box 1075
1700 BB Heerhugowaard
The Netherlands
Tel. : + 31-72-5718002
Fax : + 31-72-5714340
E-mail : info@airblast.com
Web : www.airblast.com

EDUCT-O-MATIC

1.0 INTRODUCTION

1.1 General description. The Educt-O-Matic is a light-weight, portable abrasive blasting tool with an integral abrasive recovery system. During blasting, abrasive is continually recycled, while dust and other debris are collected in a slip-on dust bag. Interchangeable adapter boots for level surfaces, corners, etc. fit over the swivel blast head to assure efficient recovery on any surface.

1.2 Principles of operation (see drawing). When the dual-seated valve is fully open, compressed air entering the tool is split into two streams. The first rushes through the air hose to the blast jet. A partial vacuum is created in the blast head at the point where this air stream passes from the blast jet to the blast nozzle, and abrasive is drawn up to this point from the abrasive container via the abrasive hose. (This is the principle of eduction which give the tool its name.) The air/abrasive mixture then passes through the nozzle and strikes the surface being blasted.

The second air stream passes along the tube at the top of the unit to the suction jet, which creates (again by eduction) the vacuum necessary for abrasive recovery. The region surrounding the adapter boot's blast cone is under vacuum whenever the tool is blasting. Abrasive, dust and debris are drawn up the outer part of the adapter boot into the main body, where abrasive is separated from lighter particles of debris and dust by cyclonic action. Abrasive falls through a screen into the abrasive container to be reused for blasting. Debris and dust spiral inward to the center of the main body, and from there move out the top and into the dust bag.

2.0 SET-UP- Air supply. The Educt-O-Matic requires 90 cfm (2.5 cbm³) at 90 psi (6.1 bar). Use a ½" (13 mm) or ¾" (19 mm) air supply line; ¾" (19 mm) is preferred. The shorter the air supply line, the better. An air filter and moisture separator are recommended to prevent clogging of the tool.

2.1 Adapter boots. The adapter boots available for the Educt-O-Matic are shown in drawing on page 4. The standard and master adapters fit onto the blast head and are held in place by friction. The four special boots fit the master adapter only. They too are held in place by friction. Make sure that the boots are properly seated before beginning to blast.

2.2 Abrasives / abrasive loading. Any standard 40 to 100 mesh blasting abrasive may be used. Fragile abrasives such as silica sand are not recommended because of the rapid breakdown of the abrasive particles which cause excessive dust and fines. Extremely sharp abrasives such as aluminum oxide and silicon carbide may be used, however the cutting action of these abrasives will cause excessive wear on the tool. For both efficiency and tool protection, Airblast recommends steel grit or iron grit. To load the Educt-O-Matic unsnap the abrasive container and place a small amount of abrasive into it. Make sure the abrasive hose is still inserted all the way into the main body after you do this. The tool may also be loaded by suction. See paragraph 3.2. Never overload the tool. Use as little abrasive as possible to reduce operational problems and extend tool life.

IMPORTANT WARNING

NEVER BLAST UNLESS THE ADAPTOR BOOT IS WELL SEALED AGAINST THE SURFACE BEING BLASTED.

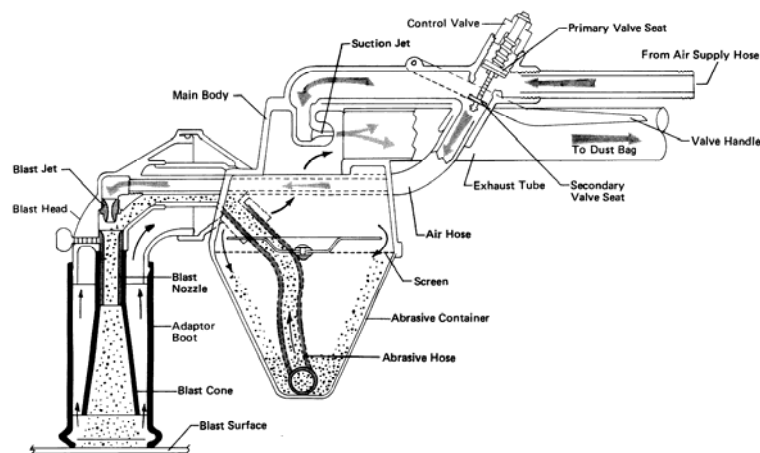

3.0 OPERATION

3.1 Handling the tool. Grip the valve handle with one hand and the adapter boot with the other hand. The main body of the tool must remain more or less upright, with the abrasive container pointing downward. The Educt-O-Matic has a swivel blast head which permits blasting in any direction (up, down, sideways) without rotating the main body. Hold the adapter boot firmly against the surface being blasted to insure a proper seal and prevent abrasive from escaping.

3.2 Dual action of the valve handle. Note that the control valve (see drawing page 1) has two seats. The first 3/16" of the valve handle's travel opens the primary seat only and the Educt-O-Matic functions essentially like a vacuum cleaner. This is because the primary seat supplies air to the suction jet only. Squeezing the handle further opens the secondary seat as well. Air is supplied to the blast jet and blasting begins.

For best abrasive recovery, hold the valve handle in the "suction only" position for two or three seconds after blasting. This will recapture any abrasive that happens to be in the blast head at the time. The "suction only" position can also be used for loading. Place a handful of abrasive on any level surface and simply suck it into the tool.

IMPORTANT WARNING
ALWAYS TURN THE AIR OFF AT THE SOURCE WHEN THE EDUCT-O-MATIC IS NOT IN USE.

4.0 MAINTANANCE

4.1 Dust bag. Empty the dust bag regularly. The dust bag is held in place by an elastic strap and by a wire-reinforced split seam on the top of the bag. The seam tucks into a metal clip on the exhaust tube. To remove the dust bag, unsnap the elastic strap, grab the end of the bag and pull it toward the main body until the place where the split seam joins together clears the end of the metal clip. The bag can be removed and shaken out. To reattach the bag, shove the exhaust tube into the bag until the end of the metal clip is beyond the place where the seam joins. Tuck both of the

reinforcing wires into the clip and pull the bag away from the main body, shoving the reinforcing wires into the clip as you pull. Don't forget to resnap the elastic.

4.2 Inspecting for blockages. The nozzle can be removed for inspection by loosening the thumb screw on the blast head. The interior passages can be inspected by unscrewing the swivel nut which connect the air hose to the blast head.

IMPORTANT WARNING

NEVER LOOK INTO THE NOZZLE WHEN THE TOOL IS CONNECTED TO A PRESSURIZED AIR SUPPLY LINE.

4.3 Adapter boot. Inspect the adapter boot regularly and replace it when excessively worn. Pay particular attention to the sleeve which fits over the blast nozzle. This sleeve protects the outside of the blast nozzle from recycling abrasive and must not be allowed to wear through.

4.4 Blast nozzle. Inspect the blast nozzle regularly and replace it when worn-out. The blast nozzle can be removed by loosening the thumb screw on the blast head. Never tighten the thumb screw more than finger tight.

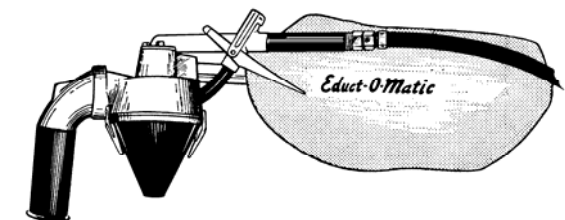

EDUCT-O-MATIC

5.0 SPARE PARTS

ART.NR.	MODEL	DESCRIPTION	
30908	AE-2000	Educt-O-Matic – USA model Includes attachment set with master adaptor Excluding brushes, hose and plywood carry case	
30909	AE-2000	Educt-O-Matic Includes attachment set with round brush and angle brush, master adaptor, 2" (50 mm) discharge hose	
30910	AE-2000	Educt-O-Matic Includes attachment set with round brush and angle brush, master adaptor, 2" (50 mm) discharge hose and a plywood carry case	
A)	30920	AE-2090	Edge attachment
B)	30930	AE-2091	Serrated attachment
	30931	AE-2091-1	Round brush (not shown)
C)	30940	AE-2092	Master adaptor
D)	30950	AE-2093	Angle attachment
	30951	AE-2093-1	Angle brush (not shown)
E)	30960	AE-2094	Flat lip attachment
F)	30970	AE-2095	Blank end
01)	30980	AE-2001	Blast head
02)	30990	AE-2002	Standard adaptor
03)	31000	AE-2004	3/8" (9 mm) nozzle – Tungsten Carbide
04)	31020	AE-2006	Blast jet
05)	31030	AE-2007	Jet gasket
06)	31031	AE-2008	Valve assembly
07)	31040	AE-2005	Thumb screw
08)	31050	AE-2011	Blast head nipple 3/8" x 4 1/4" (9 x 108 mm)
09)	31060	AE-2012	Swivel connector
10)	31070	AE-2013	O-ring
11)	31080	AE-2014	Main body
12)	31090	AE-2016	Abrasive hose
13)	31100	AE-2018	Thumb screw
14)	31105	AE-2019	Baffle washer
15)	31110	AE-2020	Hose clamp
16)	31120	AE-2021	Air hose
17)	31125	AE-2021-1	Spring for air hose
18)	31130	AE-2022	Suction jet
19)	31140	AE-2068-1	Screen assembly
20)	31150	AE-2023	Baffle (plastic only)
21)	33440	AE-2027	Locking device
22)	31160	AE-2068	Screen
23)	31170	AE-2030	Screen gasket
24)	31180	AE-2069	Abrasive container with lock and hose
25)	31190	AE-2035	Dust bag
26)	31200	AE-2032-1	Ejector pipe
27)	31201	AE-2032-2	Dust bag holder
28)	31210	AE-2042	Valve body
29)	31220	AE-2036	O-ring
30)	31221	AE-2038	Screw
31)	31222	AE-2039	Washer
32)	31228	AE-2043	Handle pin
33)	31229	AE-2044	Snap ring
34)	31230	AE-2045	Valve bushing
35)	31240	AE-2046	Valve bushing gasket
36)	31250	AE-2047	O-ring (neoprene)

EDUCT-O-MATIC

37)	31260	AE-2048	Washer
38)	31270	AE-2049	Snap ring
39)	31280	AE-2050	Primary valve spring
40)	31290	AE-2051	Valve stem
41)	31300	AE-2052	Primary valve seat
42)	31310	AE-2053	Guide washer brass
43)	31320	AE-2054	Hex nut
44)	31330	AE-2055	Washer brass
45)	31340	AE-2056	Second valve spring
46)	31350	AE-2057	Second valve seat
47)	31370	AE-2059	Washer brass
48)	31380	AE-2060	Snap ring
49)	31400	AE-2061	Pipe nipple
50)	31410	AE-2083	Rubber tube
51)	31420	AE-2065	Valve handle assembly
52)	31430	AE-2070	Swivel nut assembly
53)	21629	KIG-12	Coupling with inside thread
54)	21640	CQG-0	Gasket
55)	21684	SKG-19	Coupling with hose barb, 3/4" (9 mm) ID
56)	21682	SKG-13	Coupling with hose barb, 1/2" (13 mm) ID
57)	21723	HS-32	Hose clamp
58)	31470	AE-2120	Plywood carry case (not shown)

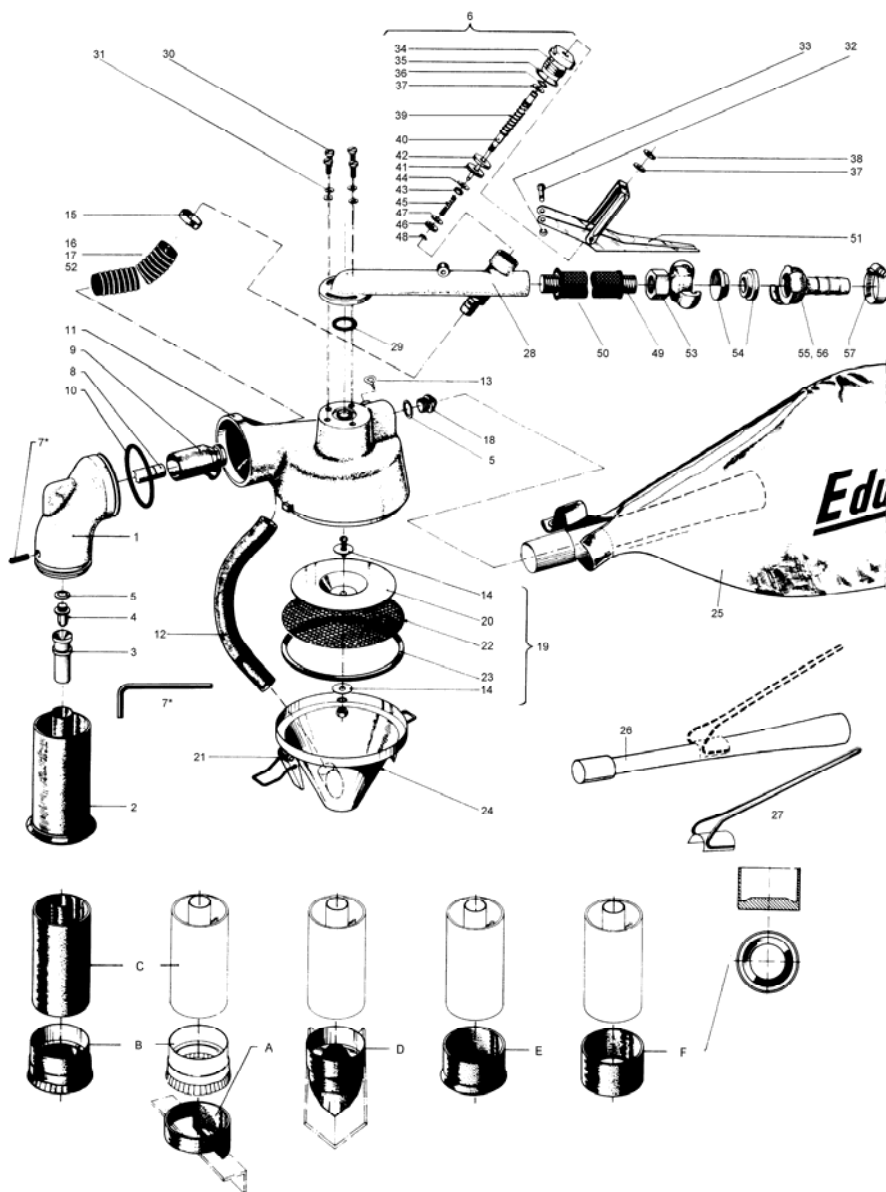

Airblast Group

Airblast B.V.

P.O. Box 1075
1700 BB Heerhugowaard
The Netherlands
Tel. : + 31 72 5718002
Fax : + 31 72 5714340
E-mail : info@airblast.com
Web : www.airblast.com

Airblast Middle East L.L.C.

P.O. Box 33419
Dubai
United Arab Emirates
Tel. : + 971 4 3242776
Fax : + 971 4 3242778
E-mail : airblast@emirates.net.ae

Airblast Saudi Arabia

P.O. Box 30476
Al-Khobar 31952
Kingdom of Saudi Arabia
Tel. : + 966 3 8473178
Fax : + 966 3 8471430
E-mail : info@airblast.com.sa

Asia Airblast Pte Ltd.

56, Tech Park Crescent
Tuas Tech Park
Singapore 638085
Tel. : + 65 6266 6010
Fax : + 65 6266 6968
E-mail : airblastsg@singnet.com.sg

AB Corrosion Control Equipment Sdn Bhd

No. 33, Jalan Permas 3/18
Bandar Baru Permas Jaya
81750 Masai, Johor Darul Takzim
Malaysia
Tel. : + 60 7357 7989
Fax : + 60 7357 7689
E-mail : airblastmy@airblastasia.org