

EXTREME AND PANORAMA SANDBLAST HELMETS

IMPORTANT WARNING FOR SAFER BLAST CLEANING

1. Use protective equipment: Abrasive-resistant clothing, safety shoes, leather gloves, ear protection, CE-approved air-fed helmet. Air for helmet must be supplied by a breathing air compressor or through a helmet air filter.
2. Check for possible silicosis hazards. Avoid dust.
3. Do not blast with damaged or worn equipment.
4. Point nozzle only at area being cleaned.
5. Use only proper dry and well-screened abrasives specifically intended for blasting.
6. Keep unprotected workers out of the blast area.
7. Before blasting:
 - Check fittings and hose for wear.
 - Safety-wire couplings together.
 - Check helmet filters and air supply.
 - Check pop-up valve for alignment.
 - Test remote controls.
 - Make sure blast machine is adequately grounded.
8. Do not weld on blast machine, this voids approval.
9. Do not substitute Airblast parts or modified equipment in any way.

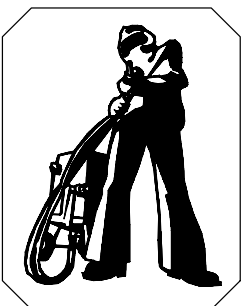

Airblast B.V.
P.O. Box 1075
1700 BB Heerhugowaard
The Netherlands
Tel. : +31-72-5718002
Fax : +31-72-5714340
E-mail : info@airblast.com
Web : www.airblast.com

1.0 INTRODUCTION.

1.1 Objectives, field of application and conditions for use

The compressed air filter system is used in a working environment where protection of the respiratory organs, face and head is required against ricocheting medium, particles, mists, vapors and gasses. When the shot-blast helmet is connected to the compressed air system, via the compressed air supply hose and the compressed air filter system, the EN 12021 filtered air flows through the entry vent at the front of the air helmet, leaving the helmet via the neck seal. The required airflow can be adjusted on the regulator. The integral airflow indicator displays whether sufficient air is passing into the shot-blast helmet. The disposable glass or plastic foil windows fitted against the helmet window can be removed when polluted or damaged. To remove, open the frame.

1.2 Limitation of usage

- The system is not suitable for working in areas with: intense heat radiation, open fires, risk of explosion or if extremely high concentrations of hazardous matter causing immediate health risk are present.
- If the ambient temperature is below the freezing point, the humidity in the compressed air circuit can result in icing-up of coupling or regulator, blocking the further supply of air. In such a case it is necessary to ensure that the humidity content in the compressed air (at atmospheric pressure) is less than 50 mg/m³, and is in accordance with EN 12021. Standard compressed air circuits do usually not comply with this requirement.
- It is not allowed to use oxygen or oxygen enriched air.
- Couplings and hose connections must be kept clean during connecting and disconnecting.
- The maximum length of the compressed air supply hose is 50 metres and the maximum pressure is 30 Bar and the hose is anti-static. The maximum temperature is 130 °C.
- The working pressure must be at least 5 Bar.
- Because of extreme human effort, it is possible that a temporary negative pressure occurs in the air hood, resulting in a reduction of the protection factor of the system.
- Air speeds in excess of 2 m/s can affect the protection factor of the complete apparatus.
- The ambient usage temperature should be between the limits of -10 °C and +60 °C.
- When combined use is made of the compressed air, for both the air hood and the air tools (e.g. paint spray) it is necessary to ensure that, at the maximum air consumption of the air tools, sufficient air is allowed to flow into the air hood. If necessary, the working pressure can be adjusted.
- The system may be used solely by trained personnel, who are also fully aware of the hazards applicable to the work being carried out.
- The shotblast helmet has no EN 397 approval regarding safety helmets.

1.3 Prior to use

Make sure that the compressor is placed in such a way that it cannot suck in any dangerous matter and the air inlet cannot be obstructed and that the compressor is switched on. Check whether the correct operating pressure is set and clean air according to EN 12021 is supplied. If not use an approved filter unit. Check if the compressor has been equipped with a suitable and adjustable pressure relief valve and has been inspected and maintained timely. Ensure that all components have been cleaned and inspected as described in paragraph 2, 3 and 4.

Adjust the working pressure on the filter system to a minimum of 5 Bar. Connect the shotblast helmet via the compressed air supply hose to the filter system. Adjust the headband to the correct length (fig. 6), and if required fit a disposable comfort hood. Fit the shotblast helmet on your head and close the neck seal to allow the creation of sufficient pressure within the air cap (fig. 7). Buckle the belt.

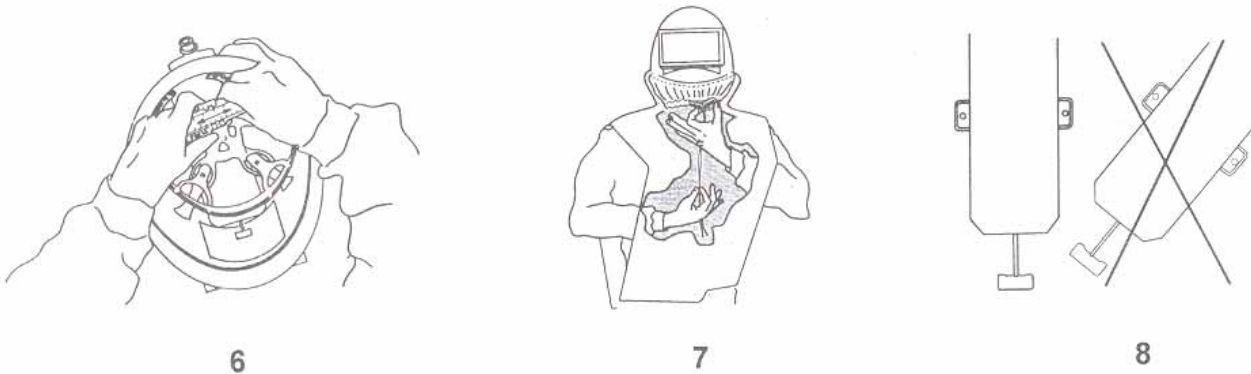

1.4 During use

Adjust the air volume according to requirements. The integrated air flow indicator warns the user if insufficient air is being supplied. The airflow indicator has been installed in such a way that the yellow pennant will not be visible when the amount of air is sufficient and it will only function when it is positioned vertically (fig. 8). For safety reasons, the regulator cannot be closed entirely. Depart the working area immediately if there is an interruption in the air supply. Ensure that the compressed air supply hose cannot be trapped, causing interference with the air supply or preventing a rapid departure from the work area. The shot blast helmet will not decrease environmental sounds. Therefore supplementary hearing protection must be used.

1.5 After use

After leaving the working area, unbuckle the belt, loosen the neck bib, take off the helmet and disconnect the air supply hose. Using a brush or a cloth, remove loose residue and dirt from the components. Clean and inspect the components according to the instructions given in paragraph 3 and 4. When connecting and disconnecting take care that no pollution enters the open hose connections.

2. Cleaning and disinfecting

After each session clean the air hood, using a mixture of water and a mild detergent (e.g. EW 80 from Tremonia Chemie, Dortmund, Germany). Subsequently, rinse thoroughly with clean water. (Do not use any solvents). The face collar or neck bib can be washed in the washing machine, using a soft detergent at 30°C. Using a disinfectant, (e.g. Incidur from Henkel) clean the inner surfaces of the air hood. Refer to the instructions given by the manufacturer. For reasons of hygiene, the same person should preferably wear the air hood. Using compressed air, blow clean the coupling and the regulator. Finally, using a dry cloth, dry all the metal components, to avoid corrosion. When cleaning, take care not to inhale hazardous matter that is released during the cleaning.

3. Maintenance and inspection shot blast helmet

Positioning the disposable windows: After opening the window frame on the helmet type Extreme, fit one disposable window (fig. 9). For type PANORAMA helmets, fit one or more disposable windows as protection for the safety glass (fig. 10).

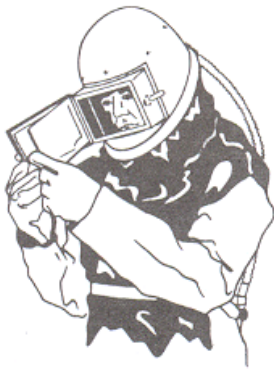

9



10

Exchanging the neck bib: The neck bib can easily be exchanged by releasing the zip.

Exchanging the cape: The bib/cape can be exchanged by shoving away the rubber helmet cover partly (fig.11).



11

Exchanging the safety glass: Open the window frame and remove the grid and the disposable windows. The glass can now be extracted out of the rubber surround. Take an original spare glass and slide this into the surround.

After replacing the components carry out a functional check.

Compressed air filter system:

For further information about the airline filter unit refer to the supplied manual documentation.

Functional check: After cleaning, disinfecting or exchanging components check the functioning of the system. Inspect all essential components for damage or pollution and, if required replace these with original spare parts. If the yellow pennant of the airflow indicator shows insufficient air in the air hood, although the pressure is correctly adjusted, this could indicate that a blockage has occurred in the filter system, the compressed air hose, coupling or silencer. During this check, hold the air hood in the vertical (normal working) position.

Checking hose system for leakages: air supply hose and coupling parts manual testing on pull force. Connect the air hood to the compressed air filter system, Adjust the supply pressure, filter system and air supply hose may not give leak sounds.

4. Maintenance frequency

Clearance to start use: Function and leakage inspection.

Prior to use: performance check for the user, check of control valve.

After use: Cleaning and disinfecting of the respirator: cleaning, functional checking and leakage inspection of the complete system.

Every 6 months: Cleaning and disinfecting of the respirator: cleaning, functional checking and leakage inspection of the complete system.

Usage duration of filters

Fluids will be drained continuously by the filtering element. Pressure lost is caused by particles on the surface and in the micro porous filling of the filtering element. It is advisable to renew the filters when a pressure difference of 0.6 Bar occurs. For safety reasons, the active carbon filter should be renewed at least every 6 months, or together with the coarse filter.

5. Storage

After use and cleaning, store the entire system in a cool, dry and dark location. Take measures to prevent component parts of the system coming into contact with oils, grease, solvents, acids or other chemicals.

ART.NR.	MODEL	DESCRIPTION
40500	EXTREME - I	EXTREME AIR SUPPLIED HELMET, COMPLETE Glass outer lens (112 x 166 mm) Standard supplied with sound silencer, heavy duty waist length plastic cape. CE-approved.
40501	EXTREME - II	EXTREME AIR SUPPLIED HELMET, COMPLETE Execution as above, fitted with leather waist length cape.
40502	EXTREME - III	EXTREME AIR SUPPLIED HELMET, BARE Exclusive of cape, belt including hose assembly.
Spare parts for EXTREME HELMET:		
1)	40220	Wire mesh screen, 110 x 165 mm
2)	40230	Glass window, 112 x 166 x 2.5 mm
3)	40240	Acrylate window, 102 x 156 x 2.5 mm
4)	40250	Rubber window gasket
5)	40506	Window assembly
6)	40508	Airflow indicator, type Extreme
7)	40280	Adjustable headband with brow pad
8)	40110	Neck bib
9)	40120	Cape - plastic
	40121	Cape - leather
10)	40540	Blouse - cotton
	40541	Blouse - leather
11)	40150	Waist belt type A
12)	40509	Adaptor
13)	40510	Corrugated hose 22 mm bore
14)	40180	Silencer type P
15)	40190	Airflow regulator
16)	40191	Nipple CEJN with ¼" inner thread
17)	40553	Cotton comfort hood

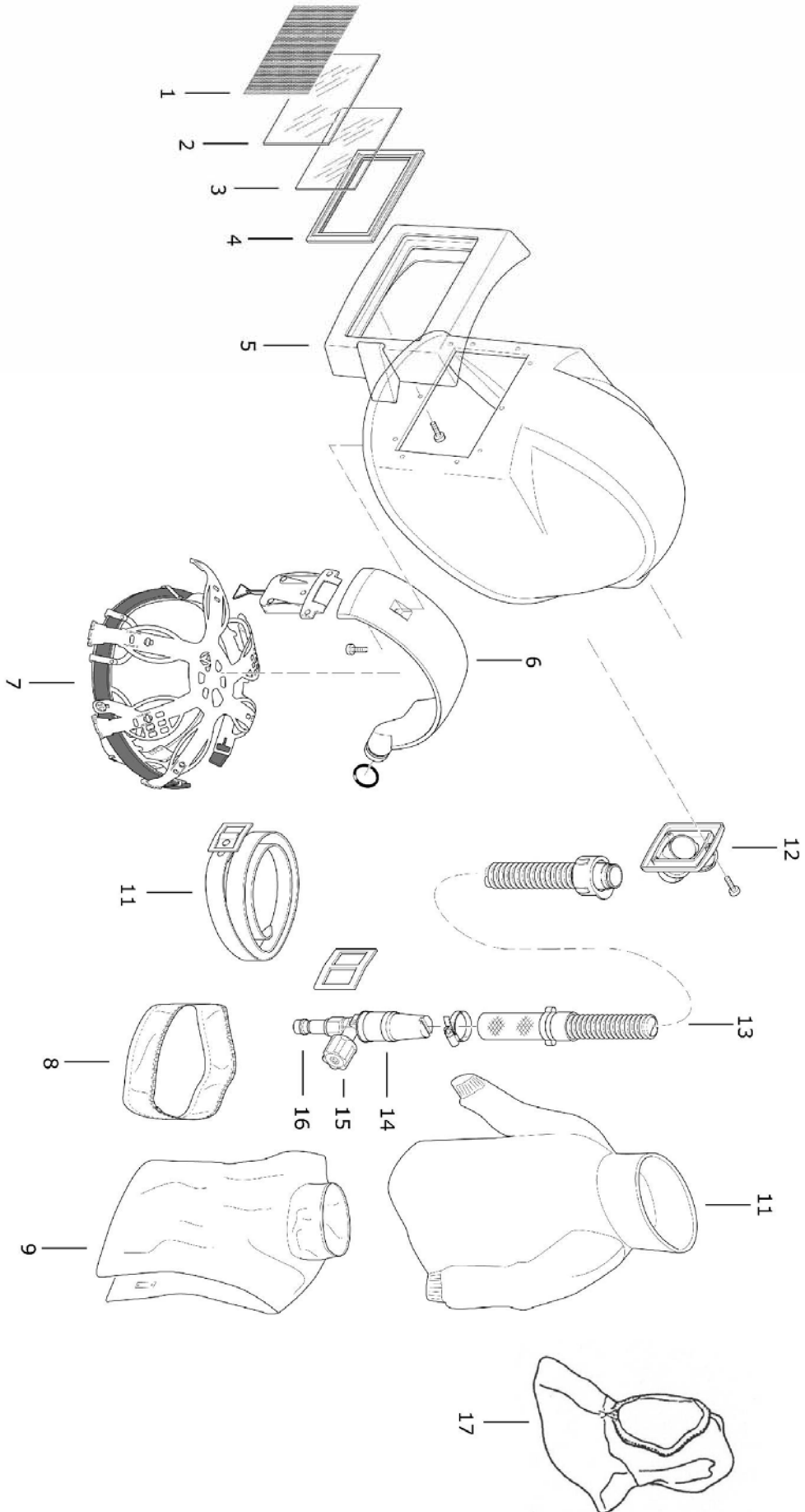

ART.NR.	MODEL	DESCRIPTION
40010	PANORAMA - I	PANORAMA AIR SUPPLIED HELMET, COMPLETE Wide view, polycarbonate window (300 x 120 mm). Standard supplied with sound silencer, heavy duty waist length plastic cape. CE-approved.
40011	PANORAMA - II	PANORAMA AIR SUPPLIED HELMET, COMPLETE Execution as above, fitted with leather waist length cape.
40012	PANORAMA - III	PANORAMA AIR SUPPLIED HELMET, BARE Exclusive of cape, belt and position 13-16 in list below.

Spare parts for PANORAMA HELMET:

- 1) 40020 Wire mesh screen, 345 x 125 mm
- 2) 40030 Disposable acetate window, 343 x 130
- 3) 40060 Window frame assembly type Panorama
- 4) 40050 Polycarbonate window, 300 x 120 x 1 mm
- 5) 40040 Rubber window gasket type Panorama
- 6) 40512 Air flow indicator type Panorama
- 40080 Air flow indicator type Panorama (old model)
- 7) 40280 Adjustable headband with brow pad
- 8) 40110 Neck bib
- 9) 40120 Cape type Panorama - plastic
- 40121 Cape type Panorama - leather
- 10) 40540 Blouse type Panorama - cotton
- 40541 Blouse type Panorama - leather
- 11) 40150 Waist belt type A
- 12) 40509 Adaptor
- 40130 Adaptor (old model)
- 13) 40510 Corrugated hose 22 mm bore
- 40140 Corrugated hose 16 mm bore (old model)
- 14) 40180 Silencer type P
- 15) 40190 Airflow regulator
- 16) 40191 Nipple CEJN with ¼" inner thread
- 17) 40533 Cotton comfort hood

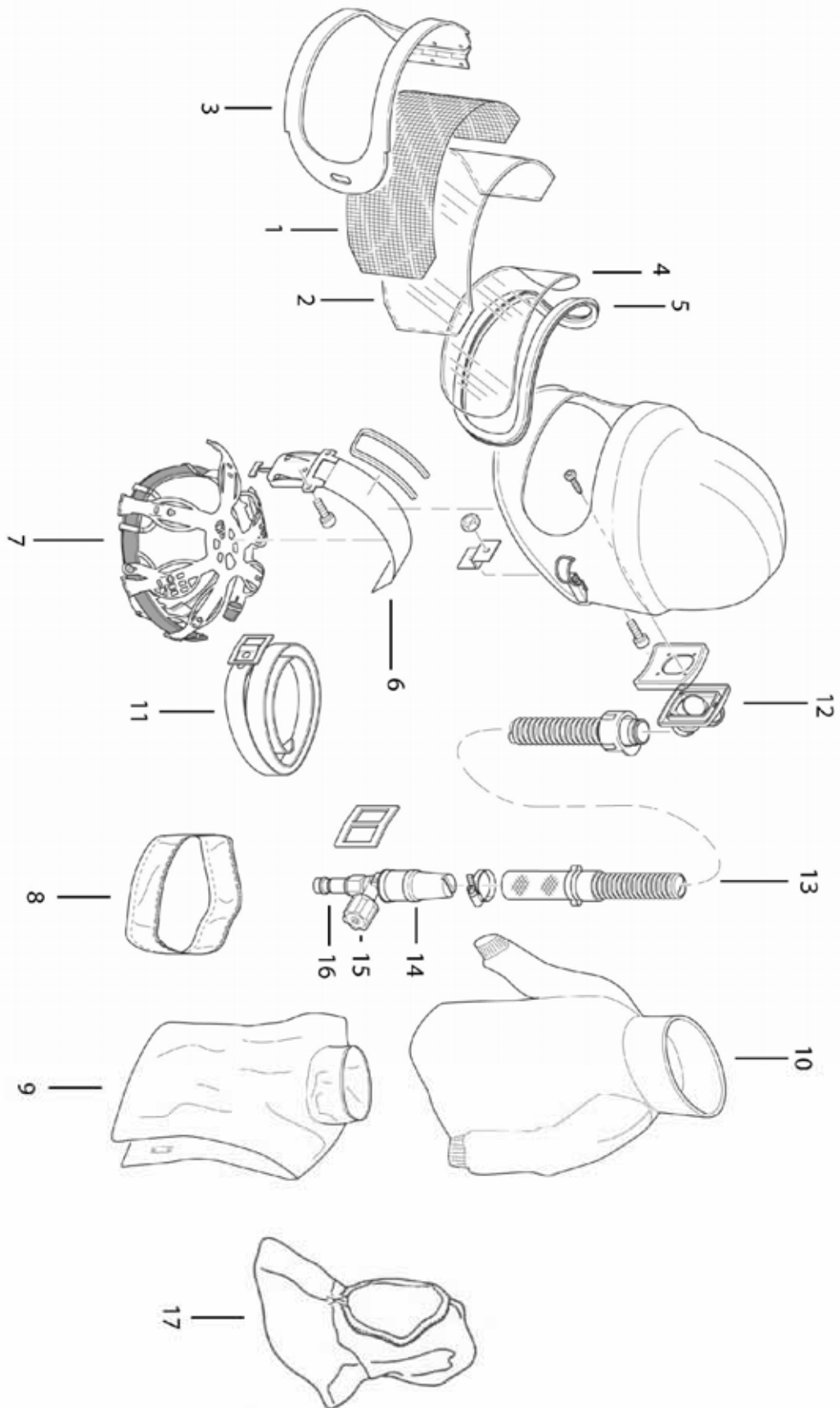

TECHNICAL SPECIFICATION		
Nominal protection factor (NPF)	1000	
Operating pressure minimum	5 bar (73 psi)	
Minimum airflow with regulator at 5 bar working pressure and 50 mtrs. hose length	165 ltr/min	
Ambient use temperature	Min.: -10 degrees C.	Max.: 60 degrees C.
Maximum hose length	50 metres	
Weight on the head	Extreme: 1400 gr.	Panorama: 1500 gr.

Statutory requirements and regulations

- 89/686/EG : European guideline for Personal protective devices (89/686/EG).
- Standard EN 271 : Respirators with compressed air hose supply for shot blasting applications
- System approval by : EXAM - BGG Prüf- und Zertifizier GmbH, Am Technologiepark 1, D-45307, Essen (German institute for research and testing)

Production control

- according to article 11A : EXAM - BGG Prüf- und Zertifizier GmbH, Am Technologiepark 1, D-45307, Essen
- Marks on the system : CE 0158

General – AIRBLAST B.V. cannot, in general terms, accept responsibility for damage incurred by the owner, user, other persons using the safety product or third parties, which results either directly or indirectly from incorrect use and/or maintenance of the safety product, including use of the product for any purpose other than that for which it was supplied and/or the non compliance or incomplete observance of the instructions contained in this user manual and/or in connection with repairs to the safety product which have not been carried out by us or on our behalf. Our general sales and Supply conditions are applicable to all transactions. AIRBLAST B.V. continually strives to improve its products and reserves the right to change the specifications mentioned in this manual without prior notification.

Warning - The European guideline "Personal Protection Means 89/686/EG" stipulates that only inspected protective bearing the CE mark may be traded and used. Use of substitute, none-original spare parts, invalidates the CE approval and, also all rights regarding guarantee. Original spare parts can be recognised by the affixed code numbers, supplemented with the manufacturer's mark and the "CE approval", possibly supplemented with a year of applicability.

Guarantee - AIRBLAST B.V. will repair or, if necessary, replace this product free of charge in the event of a material or manufacturing defect within 12 months of the purchase date, provided that the product has only been subjected to normal usage in accordance with the user manual. The guarantee is invalidated if the type or serial number marking is modified, removed or made illegible.

Airblast Group

Airblast B.V.

P.O. Box 1075
1700 BB Heerhugowaard
The Netherlands
Tel. : + 31 72 5718002
Fax : + 31 72 5714340
E-mail : info@airblast.com
Web : www.airblast.com

Airblast Middle East L.L.C.

P.O. Box 33419
Dubai
United Arab Emirates
Tel. : + 971 4 3242776
Fax : + 971 4 3242778
E-mail : airblast@emirates.net.ae

Airblast Saudi Arabia

P.O. Box 30476
Al-Khobar 31952
Kingdom of Saudi Arabia
Tel. : + 966 3 8473178
Fax : + 966 3 8471430
E-mail : info@airblast.com.sa

Asia Airblast Pte Ltd.

56, Tech Park Crescent
Tuas Tech Park
Singapore 638085
Tel. : + 65 6266 6010
Fax : + 65 6266 6968
E-mail : airblastsg@singnet.com.sg

AB Corrosion Control Equipment Sdn Bhd

No. 33, Jalan Permas 3/18
Bandar Baru Permas Jaya
81750 Masai, Johor Darul Takzim
Malaysia
Tel. : + 60 7357 7989
Fax : + 60 7357 7689
E-mail : airblastmy@airblastasia.org