

# OWNER'S MANUAL

## VORTEX AIR CONDITIONER

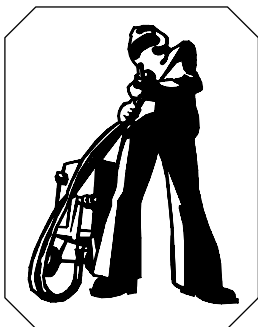

### **AIRBLAST B.V.**

P.O. Box 1075

1700 BB Heerhugowaard

The Netherlands

Tel. : + 31-72-5718002

Fax : + 31-72-5714340

E-mail : [info@airblast.com](mailto:info@airblast.com)

Web : [www.airblast.com](http://www.airblast.com)

# Vortex Air Conditioner

---

## 1.0 INTRODUCTION.

The VORTEX Air Conditioner is a device that can increase or decrease the temperature of the supplied air by approx. 20°C, so improving the working conditions of the user. The regulator for the selected Airblast blast helmet needs to be replaced by the VORTEX Air Conditioner. The VORTEX Air Conditioner is used in a working environment where protection of the respiratory organs, face and head is required against ricocheting medium, particles, mists, vapors and gases.

When the VORTEX Air Conditioner is connected to compressed air system, via the high pressure supply hose and the air filter, the breathing air according to EN 12021 simultaneously passes via the red and blue outlets and out of the device. One outlet can be used to channel the treated breathing air via the supply hose into the shotblast helmet. The required air flow and the desired temperature can be adjusted by the regulator. The air flow indicator, which is integrated in the shotblast helmet, displays whether sufficient air is passing into the helmet.

### 1.1 Usage limitations.

- The system is not suitable for use in areas with intense heat radiation, open fires, risk of explosion, or when extremely high concentrations of hazardous matter causing immediate health risk are present.
- When the ambient temperature is below freezing point, the humidity in the compressed air circuit can result in icing-up of coupling or regulator, blocking the further supply of air. In such cases, prior to use, it is necessary to determine that the humidity content in the compressed air (at atmospheric pressure) is less than 50 mg/m<sup>3</sup>, and is in accordance with EN 12021. Generally available compressed air circuits do not usually comply with this requirement.
- Before the first use of the equipment, the rapid removal of the gear needs to be practised.
- It is not allowed to use oxygen or oxygen enriched air.
- Couplings and hose connections must be kept clean during connection and disconnecting.
- The maximum permissible length of the high pressure supply hose is 50 mtrs. The maximum permissible pressure is 7 bar. The maximum permissible temperature is 60° C.
- The minimum permissible working pressure is 4.5 bar.
- The VORTEX Air Conditioner should at all times be used in combination with a shot blast helmet with integrated air flow meter.
- Exceptionally warm or cold compressed air, a long supply hose and an extreme ambient temperature could affect the performance of the VORTEX Air Conditioner.
- If the free outlets are blocked, the flow of breathing air will increase, reducing the degree of cooling or heating of the supplied air.
- The ambient usage temperature should be within -10° C. and +60° C.
- When combined use is made of the compressed air, for both the VORTEX Air Conditioner and the pneumatic tools (e.g. blast gun) it is necessary to ensure that, at the maximum air consumption of the pneumatic tools, sufficient air is allowed to flow into the air hood. If necessary the working pressure can be adjusted.
- The VORTEX Air Conditioner has no EN approval. An application has been made for an approval inspection.
- The system may be used solely by trained personnel, who are also fully aware of the hazards applicable to the work being carried out.
- All use limitations regarding the selected Airblast blast helmet remain applicable.

---

## 2.0 Use

Safe use of the VORTEX Air Conditioner is solely guaranteed when use in combination with Airblast products. Always comply with the instructions contained in this user' manual, and the user' manual for

## Vortex Air Conditioner

the Airblast blast helmet. This ensures the safety of the user, and the optimum operation of the VORTEX Air Conditioner.

### 2.1 Installing the VORTEX Air Conditioner

Disconnect the high pressure supply hose from the Airblast blast helmet. Clean and inspect the Airblast blast helmet in accordance with the relevant instructions. Fully release the original hose clamp. Draw the hose from the original regulator. Remove the original hose clamp, slide the buckle from the belt and store these together with the original regulator. Slide the belt buckle of the VORTEX Air Conditioner over the belt as shown in Fig. 1. Then slide the belt buckle down as shown in Fig. 2.

Place the hose over the desired air outlet nipple. The red nipple (Fig. 3-A) supplies warmed breathing air, and cooled breathing air flows through the blue nipple (Fig. 3-B). Keeping the opening towards the body, slide the hose clamp (Fig. 3-2) over the hose, halfway on the hose nipple. Firmly close the hose clamp, pressing with the thumb and the index finger. Ensure that the hoses for the supply of breathing air to the shot blast helmet and to the VORTEX Air Conditioner is correctly secured to the belt, and that the helmet connection of the hose for the breathing air is not leaking. Also, check that the hose is not bent and sufficiently secured against inadvertent release.

Fig. 1 Pushing the Vortex up

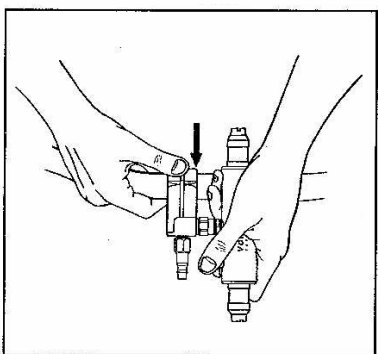
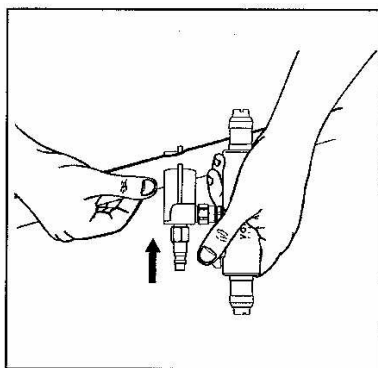

Fig. 2 Fastening the Vortex

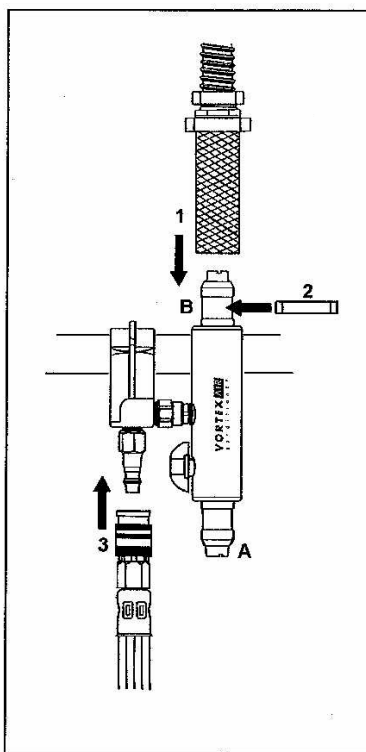

Fig. 3 Connecting the hoses

### 2.2 Prior to use.

Ensure that the compressor is switched on and that it has been set to the correct operating pressure. Check that the compressor is regularly inspected and maintained.

***A worn and/or dirty compressor supplies polluted air that will not be cleaned by the filter system! Make sure that the compressor cannot suck in any dangerous matter via the air inlet.***

Adjust the operating pressure on the filter system to 4.5 bar. Connect the VORTEX Air Conditioner via the compressed air supply hose to the filter system.

## Vortex Air Conditioner

Make sure that the VORTEX Air Conditioner is correctly secured to the belt, that the helmet connection of the hose for the breathing air is not leaking, and that the hose is sufficiently secured against inadvertent release. Continue with a test of at least two minutes.

### 2.3 During use

Adjust the temperature and the air volume according to requirements (Fig. 5). The desired temperature of the breathing air is reached within a short time. The air flow indicator in the shot blast helmet will warn the user if insufficient air is supplied.

***Immediately leave the working area if there is an interruption in the air supply.***

Ensure that the compressed air supply hose cannot be trapped, causing interference with the air supply or preventing a rapid departure from the work area. The VORTEX Air Conditioner does not reduce the environmental noises. The use of supplementary audio protection is mandatory. It is quite normal that a certain amount of air escapes from the VORTEX Air Conditioner.

Comply with the instructions relevant to the chosen Airblast blast helmet.

### 2.4 After use

After leaving the working environment, release the belt, remove the shot blast helmet and disconnect the compressed air supply hose. Clean and inspect the components according to the instructions given in paragraphs 3. When connecting and disconnecting, ensure that no pollution is allowed to enter the open hose connections.

Comply with the instructions relevant to the chosen Airblast blast helmet.

### 2.5 Switching from cold breathing air to warm breathing air and vice versa

Disconnect the compressed air supply hose. Clean and inspect the VORTEX Air Conditioner, as described in paragraph 3. Loosen the hose clamp, by pressing the ends outwards with the thumb and index finger. Turn and draw the hose from the hose nipple. Turn the VORTEX Air Conditioner by 180° and position the hose over the required exhaust vent. The red hose nipple (Fig. 4-A) near the regulator supplies warmed breathing air, and cooled breathing air flows through the blue hose nipple (Fig. 4-B). Keeping the opening adjacent to the body, slide the hose clamp (Fig. 3-2) over the hose, halfway on the hose nipple. Firmly close the hose clamp, pressing it with the thumb and the index finger. Reconnect the compressed air supply hose. Check the hose system for leakage. Check the functioning of the system.

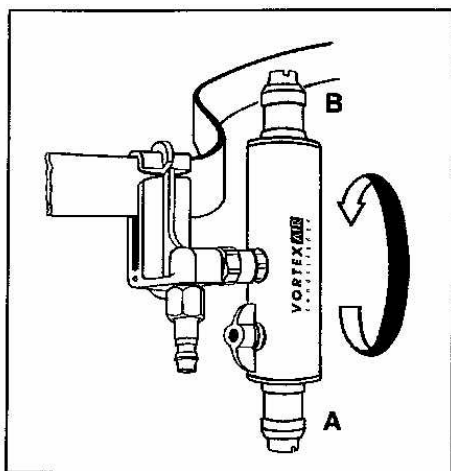

Fig. 4 Warm air / cold air

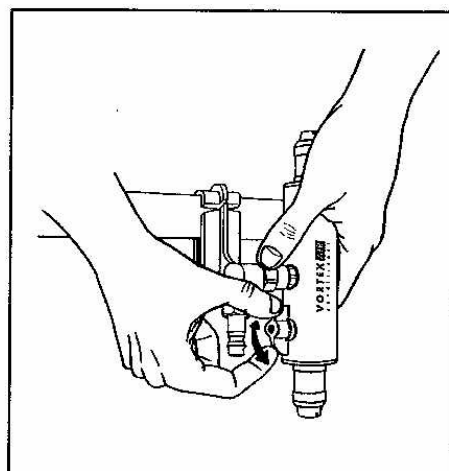

Fig. 5 Air temperature

## 3.0 Cleaning and disinfecting

After each session clean the outside of the VORTEX Air Conditioner, using water and a mild detergent. Then, wipe thoroughly clean with a cloth soaked in clean water. (Do not use any solvents). Using compressed air, blow clean the coupling and regulator. Finally using a dry cloth dry all the metal components, so avoiding corrosion. When cleaning, take care not to inhale hazardous matter that is released during cleaning.

## 3.1 Maintenance

As a result of intensive use and pollution of the compressed air system, it is possible that after some time, the noise filters get blocked with oil or dirt. These can be replaced. To remove the filters, unscrew them with a suitable screwdriver.

After replacing the components, carry out a functional check.

## 3.2 Functional check

After each cleaning, disinfecting or exchanging components, check the functioning of the system. When the air flow is correctly adjusted and the indicator shows that insufficient air is flowing into the shot blast helmet, it is essential that the defect has to be corrected first. During this check, hold the blast helmet in the vertical (normal working) position. Inspect all essential components for damage or pollution and, if required, replace these by original spare parts.

Checking the hose system for leakage: Adjust the supply pressure to 0.5 bar and then connect the shot blast helmet to the air filter system via the VORTEX Air Conditioner and compressed air supply hose. Using a suitable device, pinch the black air hose, interrupting the supply to the shot blast helmet. Then, apply soapy water with a brush to the possible areas causing the leakage. Soap bubbles clearly indicate any leakage.

## 3.3 Maintenance schedule

Prior to initial use	:	Functional test and leakage inspection.
Prior to use	:	Performance check by the user, check of regulator valve.
After use	:	Cleaning and disinfecting of the complete system.
Every 6 months	:	Cleaning and disinfecting of the complete system. Functional test and leakage inspection of the complete system. Cleaning and disinfecting of the breathing air connections.

## 3.4 Storage

After use and cleaning, store the entire system in a cool, dry and dark location. Take measures to ensure that no component parts of the system come into contact with oils, grease, solvent, acids or other chemicals.

## 3.5 Defects

There is no air supply to the helmet:

- The compressor is not switched on.
- The condensation water in the compressed air system is frozen.
- The compressed air supply hose is trapped.
- The connections are incorrectly made.
- The regulator valve for the VORTEX Air Conditioner is fully closed.
- Leakage from the compressed air system.

# Vortex Air Conditioner

## There is insufficient air flow to the helmet:

- The supply pressure is too low.
- The condensation water in the compressed air system is frozen.
- There is a blockage in the filter system.
- The compressed air supply hose is blocked or trapped.
- The connections are blocked.
- The regulator valve for the VORTEX Air Conditioner has not been opened enough.
- The noise suppressers for the VORTEX Air Conditioner are blocked.
- The breathing air supply for the shot blast helmet is blocked.
- The indicator in the shot blast helmet is defective.

## Insufficient temperature difference:

- The supply pressure is too low.
- Extremely hot or cold air from the compressor.
- The effect of a high or low outdoor temperature on a long supply hose.
- The regulator valve for the VORTEX Air Conditioner is in the wrong position.
- The noise suppressers are blocked by dirt or frozen condensation water.
- The open outlet is blocked.
- The inside of the VORTEX Air Conditioner has been ruined by foreign matter in the compressed air supply system.

Excessive air humidity, or excessive supply pressure, can cause the noise suppressor on the cold side to freeze. The air flow from the cold side will then reduce suddenly. Switch off the VORTEX Air Conditioner. After a few minutes, the VORTEX Air Conditioner will have thawed out, allowing the work to recommence. Reduce the supply pressure or change the position of the regulator valve; so avoiding reoccurrence of the freezing. A defective compressed air de-humidifier or an air de-humidifier with insufficient capacity could also be the source of such problems.

---

## 4.0 Technical specifications

Usage of the VORTEX Air Conditioner does not interfere with the protection factor NPF.

Operating pressure	: 4.5 bar dynamic
Min. supply at 4.5 bar operating pressure, with 50 m. hose	: 165 l/min
Min. compressed air usage at 5 bar operating pressure, with 50 m. hose	: 350 NI/min
Minimum ambient temperature	: -10 °C
Maximum ambient temperature	: +60 °C
Maximum hose length	: 50 m.
Noise level at 5.5 bar and maximum air flow	: 91 dB(A)
Weight on the belt	: 400 g.

# Vortex Air Conditioner

## 4.1 Performance data

Pressure	Warm		Cold		Compressed air usage
	max. flow	temp	Min. flow	Temp	
4	160	+ 18	210	- 16	350
4,5	180	+ 18	130	- 16	400
5	210	+ 18	260	- 16	430
5,5	240	+ 17	260	- 15	490

Pressure : The dynamic pressure, measured in bar (operating pressure)

Flow : The amount of transported air in liters per minute (l/min)

Temp. : The temperature difference between the incoming and outgoing air in degrees Celsius and measured after 3 minutes of operation.

The compressed air usage is measured in normal liters per minute (NI/min).

Airblast can accept no liability for damage, in the widest possible sense; of the owner, user or others involved with the use of the safety product, or third parties; occurring directly or indirectly in connection with unprofessional use and or maintenance of the safety product, including use for purposes other than those for which it is intended, and/or failure to observe totally or in part or deviations from the instructions given in this manual and/or in connection with repairs to the safety product that were not carried out by or on behalf of our company. All transactions are further covered by our General Sales and Supply conditions. Airblast strives continuously to improve it's products and reserves the right to amend the specifications as given in this manual without prior notice.

---

**4.1 Guarantee.** Airblast shall repair or replace this product free-of-charge if, after normal use and in accordance with this users manual, manufacturing faults and/or material faults occur within 6 months after the date of purchase. The guarantee lapses if the type or serial number has been changed, removed or made illegible.

## **Airblast Group**

### **Airblast B.V.**

P.O. Box 1075  
1700 BB Heerhugowaard  
The Netherlands  
Tel. : + 31 72 5718002  
Fax : + 31 72 5714340  
E-mail : info@airblast.com  
Web : www.airblast.com

### **Airblast Middle East L.L.C.**

P.O. Box 33419  
Dubai  
United Arab Emirates  
Tel. : + 971 4 3242776  
Fax : + 971 4 3242778  
E-mail : airblast@emirates.net.ae

### **Airblast Saudi Arabia**

P.O. Box 30476  
Al-Khobar 31952  
Kingdom of Saudi Arabia  
Tel. : + 966 3 8473178  
Fax : + 966 3 8471430  
E-mail : info@airblast.com.sa

### **Asia Airblast Pte Ltd.**

56, Tech Park Crescent  
Tuas Tech Park  
Singapore 638085  
Tel. : + 65 6266 6010  
Fax : + 65 6266 6968  
E-mail : airblastsg@singnet.com.sg

### **AB Corrosion Control Equipment Sdn Bhd**

No. 33, Jalan Permas 3/18  
Bandar Baru Permas Jaya  
81750 Masai, Johor Darul Takzim  
Malaysia  
Tel. : + 60 7357 7989  
Fax : + 60 7357 7689  
E-mail : airblastmy@airblastasia.org