

OWNER'S MANUAL

AIRVAC MARK III PORTABLE VACUUM RECOVERY SYSTEM

IMPORTANT WARNING FOR SAFER WORKING

1. Check for possible silicosis hazards. Avoid dust.
2. Use only proper dry and well-screened abrasives specifically intended for blasting.
3. Before use:
 - Check fittings and hose for wear.
 - Safety-wire couplings together.
4. Do not weld on blast machine, this voids Airblast and safety organization approval.
5. Do not substitute Airblast parts or modified equipment in any way.

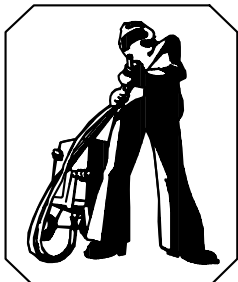

AIRBLAST B.V.

P.O. Box 1075
1700 BB Heerhugowaard
The Netherlands
Tel. : + 31-72-5718002
Fax : + 31-72-5714340
E-mail : info@airblast.com
Web : www.airblast.com

AIRVAC MARK III PORTABLE VACUUM RECOVERY SYSTEM

WARNING

THE MAXIMUM RECOMMENDED AIR PRESSURE FOR THIS UNIT IS 150 PSI (10 BAR). UNDER NO CIRCUMSTANCES MUST IT BE CONNECTED TO AN AIR SUPPLY OF GREATER PRESSURE.

1.0 INTRODUCTION. This manual covers the set-up, operating instructions and maintenance of the Airvac Mark III Portable Vacuum Recovery System.

2.0 OPERATION SET-UP. The set-up procedure for the Airvac Mark III Portable Vacuum Recovery System is as follows:

- a. Start the compressor (min. capacity: 250 cfm / 7 cbm³) and run for a period of 5 to 10 minutes to allow it to reach operating temperature.
- b. Connect a suitable length of 1½" (38 mm) I.D. air hose to the main compressor outlet.
- c. Carefully turn ON the air to "blow out" any dirt or moisture from the air hose.
- d. Turn OFF the air supply.
- e. Insert the adjustable gulper (pos. 15) into an appropriate length of 2½" (62 mm) I.D. vacuum hose and secure with a hose clip.

N.B. Although a maximum length of 100 ft. (30 m) of 2½" (62 mm) hose is recommended, the unit will still operate, with reducing efficiency, up to 200 ft. (60 m). Performance varies according to site conditions such as horizontal or vertical recovery, etc.

- f. Connect the open end of the 2½" (62 mm) hose to the suction hose coupling insert (pos. 3) and secure with a hose clip.
- g. Connect an appropriate length of 4" (100 mm) I.D. discharge hose on the discharge hose coupling (pos. 2) and secure with a hose clip.

N.B. The maximum recommended length of discharge hose is 40 ft. (12 m).

- h. Locate the discharge end of the 4" (100 mm) hose into a suitable hopper or waste skip etc.

- i. Turn off the air valve (pos. 11) i.e. with the handle at 90 degrees to the valve.
- j. Connect the air hose to the air valve (pos. 11) using a 1½" (38 mm) male / male nipple.

3.0 OPERATION

3.1 Turn ON the air at the compressor.

3.2 Turn ON the air valve (pos. 11).

3.3 With the adjustable gulper (pos.15) drawing free air only ensure that the pressure gauge (pos. 7) is reading a min. of 80 psi (5.4 bar) and the vacuum gauge (pos. 8) is reading between 1.8" and 2.2" Hg. If either gauge does not read as above, see paragraph 5.

3.4 If the intermittent flow of abrasive is observed, slowly open the adjusting ring on the gulper after releasing the Allen screw with the key provided. When a smooth flow is obtained lock the ring in position with the Allen screw.

3.5 If the rate of recovery is too slow the adjusting ring can be closed slightly as above, to increase the flow.

3.6 When the work has been completed or the Airvac is left unattended always turn OFF the compressor, then air valve (pos. 11) before disconnecting the hoses etc.

4.0 MAINTENANCE.

N.B. Ensure that the air supply at the compressor is turned OFF and that the air line is purged of pressure before maintenance work is carried out.

In order to keep the Airvac operating at maximum efficiency and keep wear to a minimum it is imperative that the following maintenance procedures are carried out.

4.1 After 8 working hours. Remove the venturi sheath (pos. 6) from the main body by turning anti clockwise. Turn the venturi tube (pos. 1) one eighth of a full turn within the sheath and refit the assembly to the body.

4.2 Where the unit is not fitted with a primary air filter immediately adjacent to the air valve (pos.11) the nozzle (pos. 10) should be removed frequently and checked. This is carried out by:

AIRVAC MARK III PORTABLE VACUUM RECOVERY SYSTEM

- a. Removing the venturi sheath and mixing chamber (pos. 5) together thus giving access to the nozzle.
- b. Using the nozzle key (pos. 25) in the radial by-pass slots, unscrew the nozzle by turning anti clockwise.
- c. The nozzle radial slots should be cleaned and examined for uneven wear. Inspect the 7 nozzle ports and clear any obstructions taking care not to damage the surfaces, which are machined to fine tolerances to ensure optimum efficiency. Should any of the nozzle ports be worn or damaged the nozzle should be discarded and a new one fitted.
- d. Before replacing the nozzle clean out any foreign matter remaining in the manifold ports and clean the threads of both aerofoil (pos. 17) and nozzle. Replace the nozzle using the key provided taking care to start the finely pitched thread correctly then tighten until the machined shoulders of the aerofoil and nozzle are firmly mated.

WARNING

A BLOCKED OR DAMAGED NOZZLE WILL CAUSE NOT ONLY A DROP IN PERFORMANCE BUT ALSO TURBULANCE WHICH WILL CAUSE RAPID WEAR OF BOTH THE PUMP BODY AND THE VENTURI TUBE.

- e. Inspect the mixing chamber (pos. 5) for excessive wear and replace if necessary. Refit the mixing chamber and venturi assembly ensuring that the identification groove is towards the pump end.

4.3 Removing the suction hose coupling (pos. 4). Release the camlocks and remove any debris, which may be trapped in the rear of the pump. Examine aerofoil (pos. 17) for excessive wear and blockages, suction hose coupling insert (pos. 3) for excessive wear and where necessary replace worn parts.

4.4 Replacement of venturi tube (pos. 1). Remove the venturi sheath (pos. 6) from the mixing chamber (pos. 5) by un-screwing it in an anti-clockwise direction. Place the protruding outlet of the venturi tube on the floor and push down the sheath. Pull up the venturi tube by pulling against the cam levers. Fit the new venturi tube after cleaning the location recess. Fitting is the reverse operation.

4.5 Replacement of the suction hose coupling insert (pos. 3). Remove the suction hose-coupling insert by opening the camlocks on the body coupler (pos. 20). Slacken the socket screws on the suction hose coupling (pos. 4) approximately 4 full turns and knock out the coupling insert. Clean locations shoulder and fit new insert. Tighten each screw until the insert is retained in the coupling but can still be rotated inside it. Tighten the socket screws evenly until tight, observing inward pull of insert onto sealing face of coupling, ensuring seal ring (pos. 26) is in position.

4.6 Replacement of the aerofoil. Remove the venturi tube and mixing chamber together, nozzle and suction hose coupling as previously described.

Remove the four socket head screws (pos. 23) securing the manifold assembly (pos. 12) to the pump body (pos. 18). Remove the two central screws in the pump body either side of the inlet port and also the two remaining screws diametrically opposite pos. 21 and 22. Using a piece of timber suitably notched tap the aerofoil out in the direction of the venturi. Clean any remaining gasket material from the manifold, inlet flange and pump interior. Offer the new aerofoil to the body and check that only light tapping will be required to fit in place. If the aerofoil is obviously a tight fit trim down the new aerofoil on the side opposite the air inlet only by rubbing with wetted P120 wet and dry paper.

When the aerofoil is correctly trimmed smear the air inlet side of both the body and the aerofoil with gasket compound and immediately tap the aerofoil into place in the body using a wooden dowel inserted in the nozzle port. Align the inlet ports of both body and aerofoil then insert and tighten the two long countersunk screws on either side of the inlet port. Leave the gasket material to harden for 1 hour then replace the two short countersunk screws on the side opposite the air inlet and tighten. With the remaining rubber compound make a fillet round the aerofoil where it touches the body on both sides and using a spreader smooth into any crevices particularly on the side opposite the air inlet. Apply gasket compound to both body and manifold flanges and fit new manifold gasket (pos. 12) taking care to align the central hole correctly. Replace the manifold assembly securing with the four socket head screws and replace the nozzle in the aerofoil. Allow 1 hour for gasket compound to cure then connect pump to air supply and check for leaks around aerofoil and manifold joint faces. Refit inlet body coupler and mixing chamber venturi tube.

AIRVAC MARK III PORTABLE VACUUM RECOVERY SYSTEM

5.0 TROUBLESHOOTING

PROBLEM	CAUSE	REMEDY
Pressure gauge (pos. 7) reads below 80 psi (5.4 bar)	Air valve (pos. 11) or outlet valve on compressor not fully open.	Open valves fully.
	Airline couplings not tight or gaskets missing.	Tighten couplings, check and replace gaskets if required.
	Compressor operating below pressure.	Check compressor. N.B. Compressor maintenance should only be carried out by competent person.
	Nozzle (pos. 10) worn.	Check and replace if necessary.
	Aerofoil (pos. 17) worn out.	Check and replace if necessary.
Vacuum gauge (pos. 8) reads 1.8 Hg	Pressure gauge (pos. 7) reads below 80 psi (5.4 bar).	See 4.1
	Air leaks at suction hose coupling.	Check action of camlock, check And replace seal ring (pos. 26) if necessary.
	Air leaks around aerofoil (pos. 17).	Check, reseal or replace as necessary.
	Nozzle (pos. 10) worn or not sealing correctly.	Check and replace as necessary.
	Venturi tube (pos. 1) worn.	Remove 2½" (62 mm) suction hose, place flat blanking plate over end of suction hose coupling insert (pos. 3). If vacuum gauge reads below 13.5 Hg. replace venturi tube.
	Excessive length of 4" (100 mm) discharge hose fitted, max. recommended-40 ft. (12 mtr.)	Reduce length if necessary.
	Intermittent flow of abrasive.	Insufficient air flow through recovery hose. Slowly open adjusting ring on gulper head (see 2.5) until smooth flow achieved.
Very poor recovery rate.	Excessive air flow through recovery hose. Slowly adjust ring on gulper head (see 2.5) to restrict air flow.	
	Blockage in pump body (pos. 18).	Remove suction hose coupling, check and clear blockages around aerofoil.
	Blockage in suction hose.	Remove and clear blockages.

AIRVAC MARK III PORTABLE VACUUM RECOVERY SYSTEM

6.0 SPARE PARTS

ART.NR.	MODEL	DESCRIPTION
30640	AIRVAC MARK III	Portable vacuum recovery system complete. Weight: 27 kgs.
01)	30650 AV - 1	Venturi tube
02)	30660 AV - 2	Discharge hose coupling
03)	30670 AV - 3	Suction hose coupling insert
04)	30680 AV - 4	Suction hose coupling
05)	30690 AV - 5	Mixing chamber
06)	30700 AV - 6	Venturi sheath
07)	30710 AV - 7	Pressure gauge
08)	30720 AV - 8	Vacuum gauge
09)	30730 AV - 9	Discharge coupler
10)	30740 AV - 10	Nozzle
11)	30750 AV - 11	Air valve
12)	30760 AV - 12	Manifold assembly
13)	30770 AV - 13	Pump assembly (body with aerofoil fitted)
14)	30780 AV - 14	Restrictor
15)	30790 AV - 15	Gulper (adjustable)
17)	30810 AV - 17	Aerofoil
18)	30820 AV - 18	Body
19)	30830 AV - 19	Leg bracket
20)	30840 AV - 20	Body coupler
21)	30850 AV - 21	Location screws – short (2 per set)
22)	30860 AV - 22	Location screws – long (2 per set)
23)	30870 AV - 23	Manifold screws (4 per set)
24)	30880 AV - 24	Manifold gasket
25)	30890 AV - 25	Nozzle key
26)	30900 AV - 26	Seal ring (camlock)
21830	2½" (62 mm) hose	2½" (62 mm) antistatic flexible plastic hose
21840	4" (100 mm) hose	4" (100 mm) antistatic flexible plastic hose

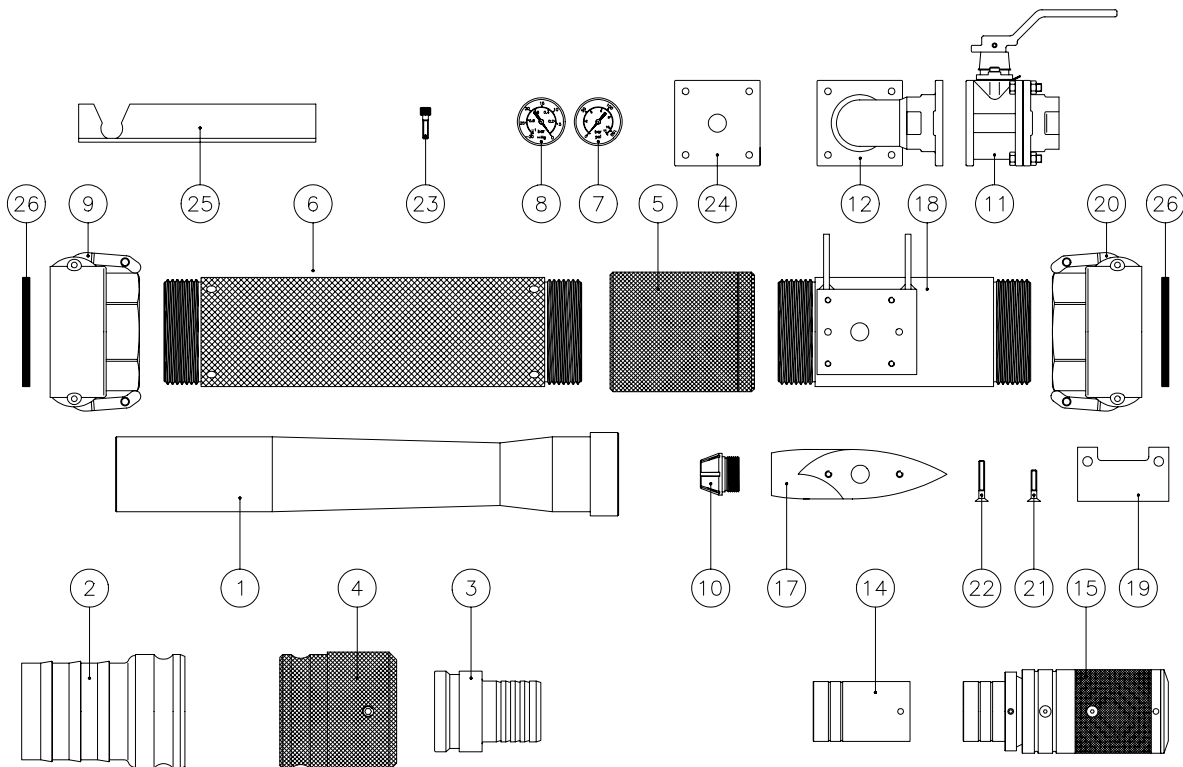

AIRVAC MARK III PORTABLE VACUUM RECOVERY SYSTEM

Airblast Group

Airblast B.V.

P.O. Box 1075
1700 BB Heerhugowaard
The Netherlands
Tel. : + 31 72 5718002
Fax : + 31 72 5714340
E-mail : info@airblast.com
Web : www.airblast.com

Airblast Middle East L.L.C.

P.O. Box 33419
Dubai
United Arab Emirates
Tel. : + 971 4 3242776
Fax : + 971 4 3242778
E-mail : airblast@emirates.net.ae

Airblast Saudi Arabia

P.O. Box 30476
Al-Khobar 31952
Kingdom of Saudi Arabia
Tel. : + 966 3 8473178
Fax : + 966 3 8471430
E-mail : airblast@awalnet.net.sa

Asia Airblast Pte Ltd.

56, Tech Park Crescent
Tuas Tech Park
Singapore 638085
Tel. : + 65 6266 6010
Fax : + 65 6266 6968
E-mail : airblast_sg@pacific.net.sg

AB Corrosion Control Equipment Sdn Bhd

No. 33, Jalan Permas 3/18
Bandar Baru Permas Jaya
81750 Masai, Johor Darul Takzim
Malaysia
Tel. : + 60 7357 7989
Fax : + 60 7357 7689
E-mail : airblastmy@airblastasia.org