

Airblast B.V.

P.O. Box 1075
1700 BB Heerhugowaard
The Netherlands
Tel.: +31-72-5718002
Fax: +31-72-5714340
E-mail: info@airblast.com
Web: www.airblast.com

Commercial Information

The Art of Powerful Cleaning...

Doc./Version/Date: ABPB01-0602

Title: AIRBLAST INTERNAL PIPE CLEANING/COATING EQUIPMENT

Internal pipe cleaning and coating faster, easier, and more economical.

Now, rotary clean and coat the full 360' inside of pipe surfaces from 6" (150 mm) to 381" (9700 mm) in diameter easier, faster and more economically with the Airblast PipeBlasters types 1010, 1020 and 1030 and coating types 2010, 2020 and 2030 and easily connect them to your standard blast pot, painting unit and air compressor without requiring additional equipment.

The highly efficient system removes mill scale, corrosion, rust, old coatings and other contaminants faster with less manpower and equipment. Equipment costs are lowered by eliminating expensive scaffolding, multiple blast pots, multiple air compressors and hoses. Using only two to three men to operate, the PipeBlaster system reduces labour costs substantially over blast-pot operations requiring a dozen men.

What's more, with the PipeBlaster, you get one machine that adapts to all media types, pipe sizes, container shape and adapts for Epoxy and coating applications. Plus, its sharp accuracy provides precise surface profiles rarely found with hand-held blast pot operations.



It's a white tornado in a pipe.

The Airblast PipeBlaster's powerful self-propelled air blast cleaning system applies the same direct force as standard blast nozzles cleaning to white metal at rates faster than any other means.

Reduces Hazards.

With pipes 24 inches (610 mm) and larger, the self-propelled PipeBlaster cart is driven into the pipe using remote controls to reduce hazards.

Adapts to Media, Pipe Sizes and Shapes

Not only does the PipeBlaster adapt to pipes from 6" to 381" (150 to 9700 mm), it also uses a variety of media to clean the inside of tanks, tanker trucks, ships, vessels and metal containers. And it easily adapts to apply epoxy coating for internal pipe lining.

No Down-Time

No time wasted stopping and dealing with equipment problems. With the Airblast PipeBlaster reliability you keep right on cleaning.

Eliminates Human Error

PipeBlaster engineering provides for precise uniform cleaning rates and eliminates human error commonly

The PipeBlaster Process

The system consists of a self-propelled cart, rotary head, rotary diffuser and venturi nozzles. For pipes larger than 24 inches, the self-propelled unit moves forward or reverse through the pipe as a rotating head with 2 or 3 venturi nozzles blasts abrasive onto the interior pipe surfaces. For small pipes and closed vessels a guided boom with rotating head assembly can be provided.

Nozzles adjust from 15 to 90 degrees forward or reverse to further improve the efficiency for specific applications and to maximize cost savings, blast media can be recycled, cleaned and reused many times over with a Recovery and Reclaim System.

Ordering Information Blasting Units

Stock Number : 1010 : 6" - 70" (150 -1800 mm), self-propelled after 24"
1020 : 47" - 141" (1200 -3600 mm)
1030 : 70" - 381" (1800 mm - 9700 mm)

Ordering Information Painting Units

Stock Number : 2010 : 6" - 70" (150 - 1800 mm)
2020 : 47" - 118" (1200 - 3000 mm)
2030 : 70" - 374" (1800 - 9500 mm)

Specifications

Cleaning Rate : Average: 1,500 to 3,000 sq ft/hr (75 to 200 sqm), dependent upon pipe surface condition, CFM (cbm/m) available, size/type of nozzle and required cleaning criteria)

Head Rotation : 30 - 70 RPM

Usable Blast Media : Common abrasives

Air Pressure : 80 - 150 psi (5.4 - 10.2 bar)

Air Requirement : 600 - 800 CFM (17 - 23 cbm/m) for 1010

1100-1300 CFM (32 - 37 cbm/m) for 1020 and 1030

Electrical : Voltage: 110 v, single phase, Frequency: 60 Hz, Amps: 20 (Options include: 220 volts, other special voltage and frequency requirements plus air motors and explosion proof systems).



Pipeblaster 1010, configured for pipes of 24" to 48" ID.

Delivery includes (1010):

One (1) extra wear tube
External Operation Control Panel
Diameter Adjustments
Two Rotary Diffusers @ 15 and 90 degrees
Blast Hose Coupling Connector
Prepared for Shipment
Owners Manual

Delivery excludes (1010):

Blast Nozzles
Blast Hose
Shipping and Freight
Field Service
Air Compressor
Blast Pot

Delivery includes (1020 and 1030):

One (1) extra Wear Tube
Diameter Adjustments
Three (3) Outlet Discharge Turret
Out-Rigger Stabilizers (1030 only)
Blast Hose Coupling Connector
Blast Nozzle Couplings (3)
Prepared for Shipment
Owners Manual

Delivery excludes (1020 and 1030):

Blast Nozzles
Blast Hose
Shipping and Freight
Field Service
Air Compressor
Blast Pot
Lance Centering Tool

Delivery includes (2010, 2020 and 2030): Delivery excludes (2010, 2020 and 2030):

Three (3) 40 ft, 1/2" Air Hose
Explosion Proof Air Motors
Air Regulators
External Control Panel
Flow Meters
Two (2) Spare Swivels
Diameter Adjustments
Prepared for Shipment
Owner's Manual

Airless Pumps and related Equipment
Air Compressor
Spray Tips
Shipping and Freight
Valves

Performance Guarantee : Airblast B.V. guarantees the equipment to be free of defects and in good working condition for a period of sixty (60) days provided the equipment has not been damaged or altered in any way. Should any part or item fail or prove to be defective within the sixty (60) day guarantee, that item or part will be replaced by Airblast. Airblast does not guarantee "wearable items" such as blast hose, blast nozzles, couplings etc. nor does Airblast guarantee the electric motors since they are covered under the manufacturers warranty.

General Notes : Regarding "wastage of spinning parts...". The only spinning parts that come into contact with the blast grit is the Wear Tube and the Rotary Diffuser. These parts are guaranteed to last a minimum of 1000 working hours using any type of blast grit. Replacement of these parts takes 10-15 minutes. All bearings, seals, rings, etc. do not come into contact with the blast grit, thus making the unit(s) extremely reliable. The Airblast PipeBlasters are built for "heavy-duty" blasting applications.

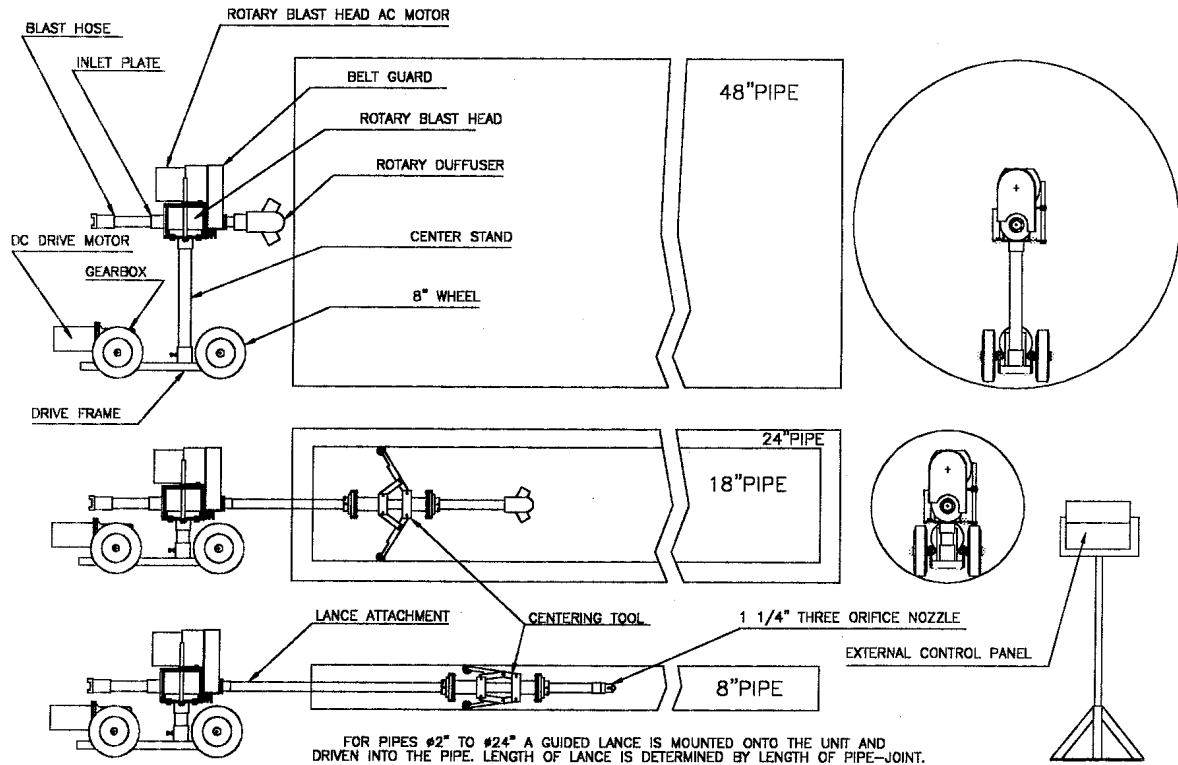

Airblast 1010

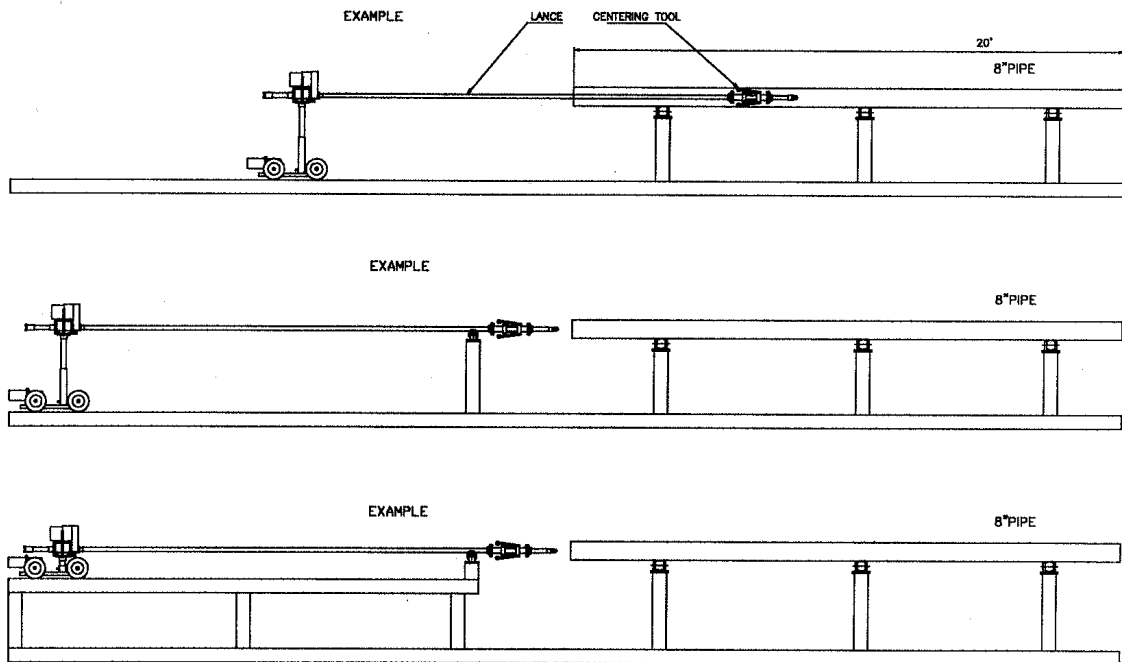

Airblast 1010

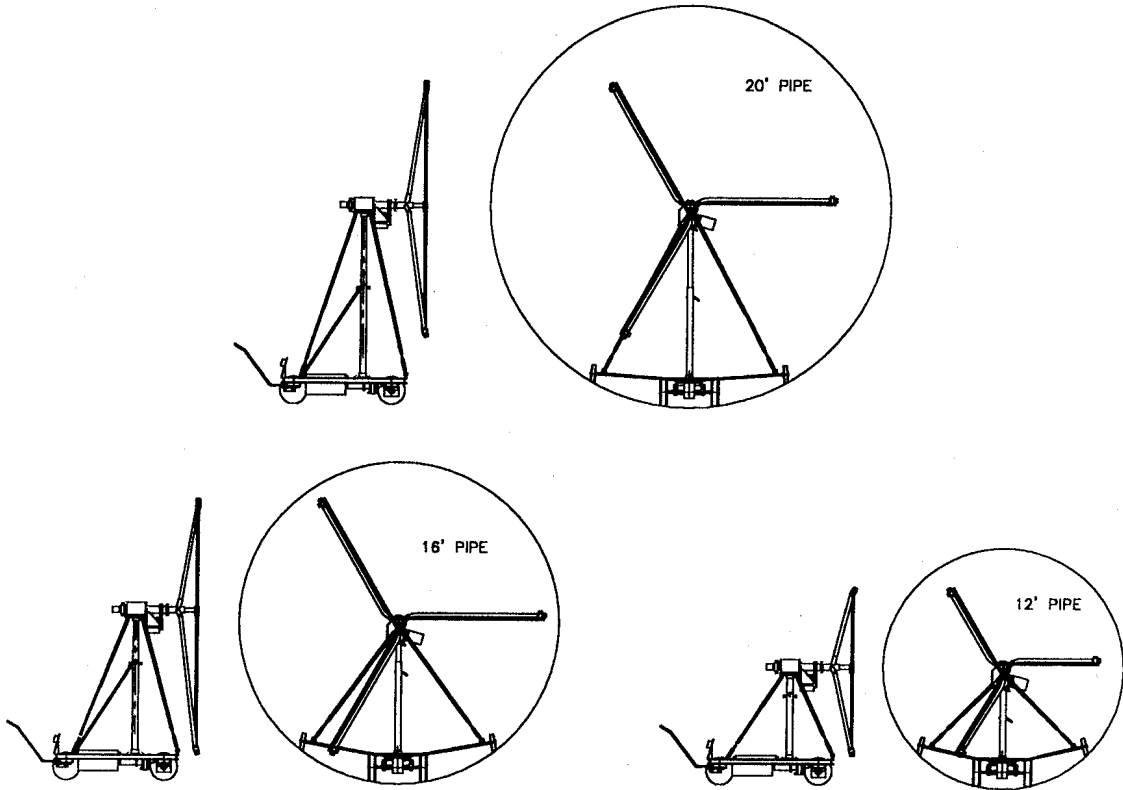

Airblast 1030

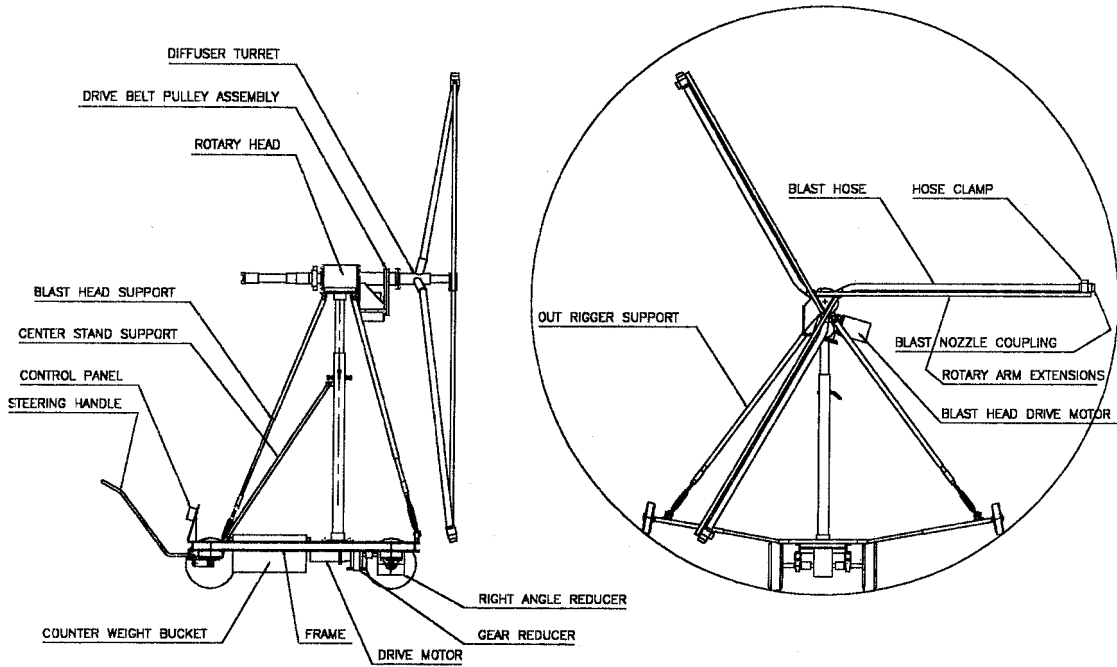

Airblast 1030

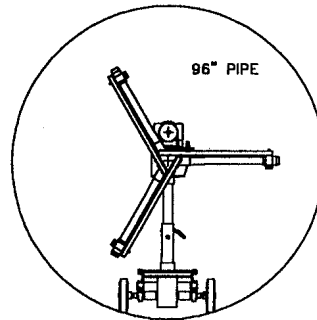
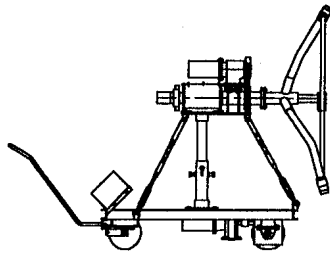
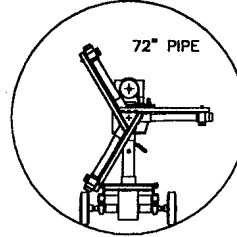
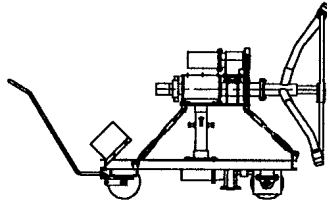
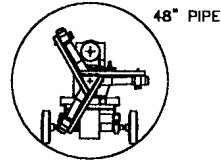
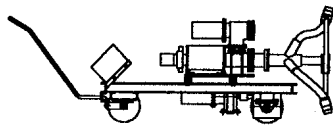

Airblast 1020

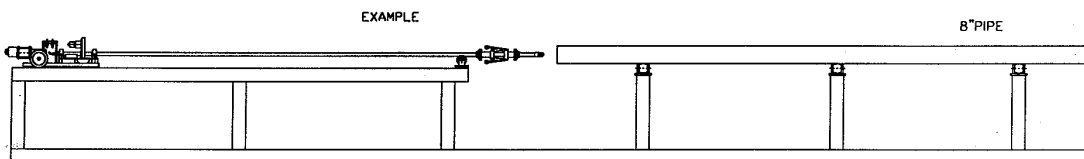
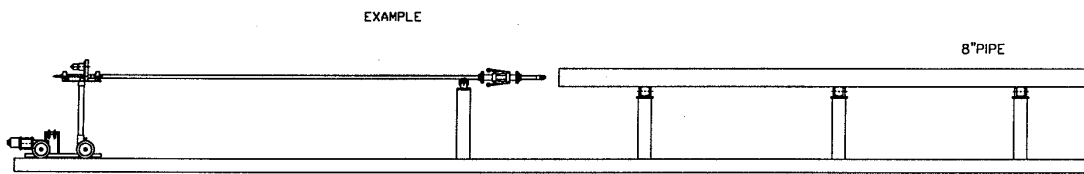
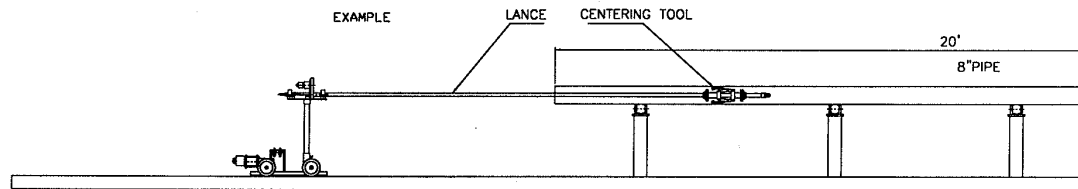

Airblast 2010

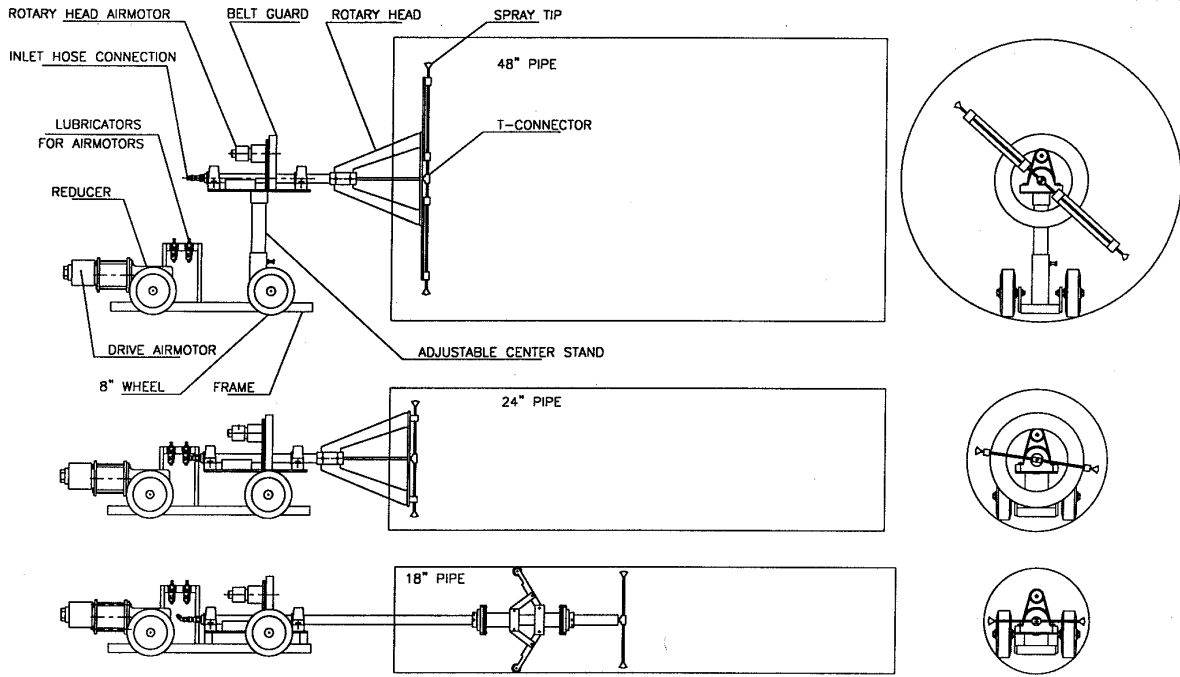

Airblast 2010

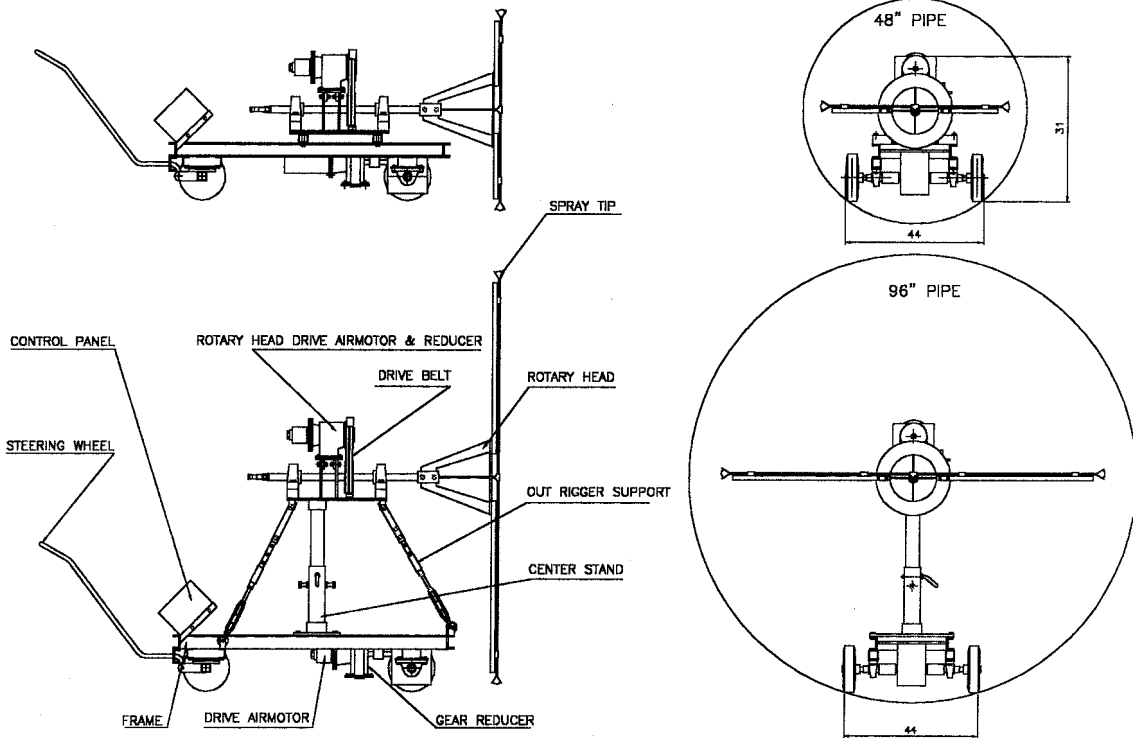

Airblast 2030